

Tube-Line Bale Feeder BF 5000SL

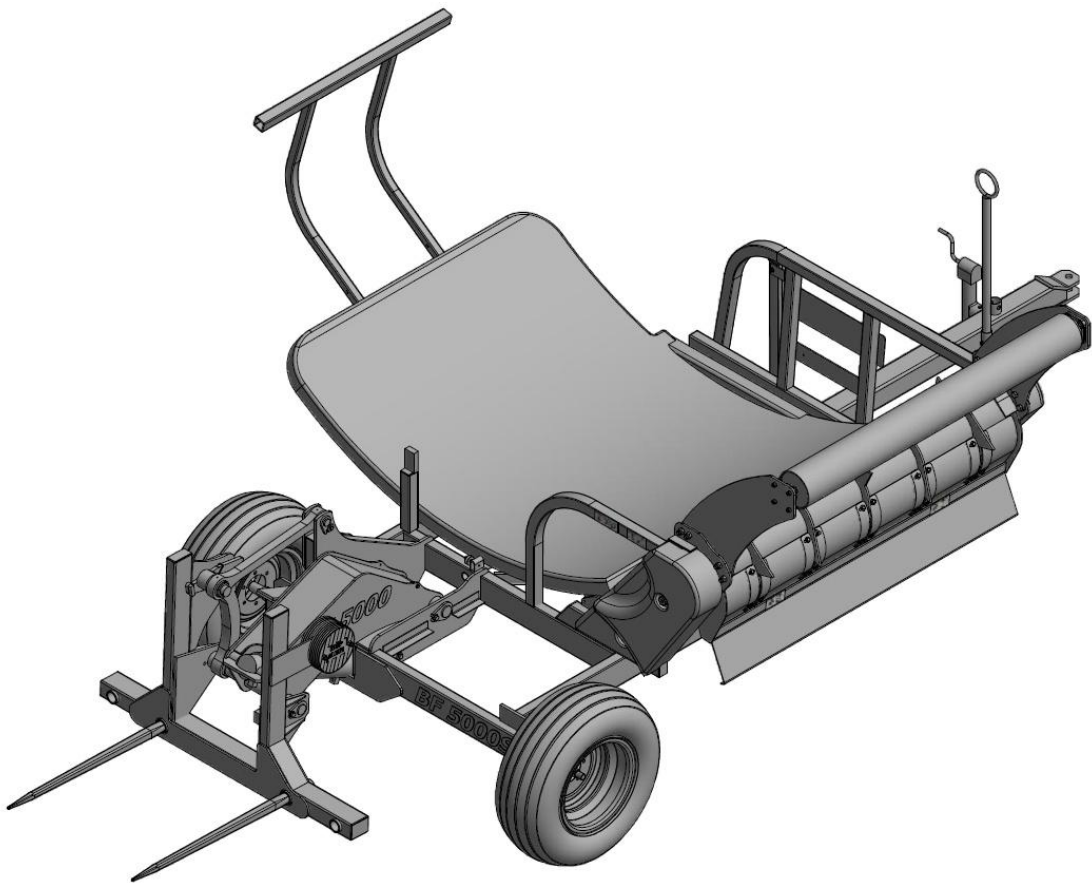

TUBE-LINE™
MANUFACTURING LTD

30608 (18/02/15)

TO THE OWNER

This manual contains information concerning the adjustment, assembly and maintenance of your Tube-Line Chainless Bale Feeder. You have purchased a dependable machine, but only by proper care and operation can you expect to receive the performance and long life built into the Bale Feeder. Please have all operators read this manual carefully and keep it available for ready reference.

Your authorized dealer will instruct you in the general operation of your Bale Feeder. Your dealer's staff of factory-trained service technicians will be glad to answer any question that may arise regarding the operation of your Bale Feeder.



This safety alert symbol indicates important safety messages in this manual. When you see this symbol, carefully read the message that follows and be alert to the possibility of personal injury or death.



Pictures in this manual may show protective shielding open or removed to better illustrate a particular feature or adjustment. Be certain, however, to close or replace all shielding before operating the machine

Improvements

Tube-Line Manufacturing Inc. is continually striving to improve its products. We reserve the right to make improvements or changes when it becomes practical and possible to do so, without incurring any obligation to make changes or additions to the equipment sold previously.

Contents

Safety.....	5
Parts	15
General information.....	34
Operation.....	40
Lubrication	42
Maintenance.....	44
Troubleshooting.....	45

Precautionary Statements

Personal Safety

Throughout this manual and on machine decals you will find precautionary statements (“DANGER”, “WARNING”, and “CAUTION”) followed by specific instructions. These precautions are intended for the personal safety of you and those working with you. Please take time to read them.



DANGER

This word “DANGER” indicates an immediate hazardous situation that, if not avoided, will result in death or serious injury.



WARNING

This word “WARNING” indicates a Potentially Hazardous situation that, if not avoided, could result in death or serious injury.



CAUTION

This word “CAUTION” indicates a potentially hazardous situation that, if not avoided, May result in minor or moderate injury. It may also be used to alert against unsafe practices.
Failure to follow the danger warning and caution instructions
May result in serious bodily injury or death.

Machine Safety

The precautionary statement (“important”) is followed by specific instructions.
This statement is intended for machine safety.

IMPORTANT : The word “IMPORTANT” is used to inform the reader of something he Needs to know to prevent minor machine damage if a certain procedure is not followed.

Safety

Precautionary Statements

A careful operator is the best operator. Most accidents can be avoided by observing certain precautions. To help prevent accidents read the following precautions before operating this equipment. Equipment should be operated only by those who are responsible and instructed to do so.

Carefully review the procedures given in this manual with all operators. It is important that all operators be familiar with and follow safety precautions.

1. When transporting the machine on public roads, make sure the machine is in compliance with all local road regulation.
2. Before operating the unit be sure that it is assembled correctly and in good operating condition.
3. If machine maintenance work, repairs or adjustments must be done in the field, they should be done at a spot where the ground is firm and level. Turn off the tractor and apply the parking brake. Use the proper tools and wear suitable protection (safety goggles, work gloves, etc.).
4. If any maintenance work, repairs or adjustments are done which require disassembly, always make sure that everything is reassembled or retightened as it has been prior to making repairs or adjustments.
5. Follow the schedule provided for maintenance. By following these suggestions, it will be possible to keep the machine operating safely and efficiently, to the benefit of the user.
6. General checking of bolts, security pins and split pins must be carried out initially after the first 8 hours of use. Subsequently, check every 50 hours and whenever the machine is laid up for extended periods.
7. Before applying pressure to the system, be sure all connections are tight and that hoses and connections are not damaged.
8. Fluid under pressure can have sufficient force to penetrate the skin, causing serious personal injury. Always protect the skin and eyes from escaping fluid under pressure. If injured by escaping fluid, obtain medical assistance at once. Serious infection or reaction can develop if medical treatment is not administered immediately.
9. Do not weld on wheels. Welding on wheels may cause high stress and a wheel failure.
10. Do not weld on wheels with a mounted tire. Welding on wheels with a mounted tire may cause the tire to burst, causing serious injury or death.
11. Before leaving the cab, engage the parking brake, shut down engine, and wait for all moving parts to stop.
12. Always keep bystanders away from machine during operation, Rotating elements may cause serious bodily injury.

General Safety

YOU are responsible for the safe operation and maintenance of your Tube-line Chainless Bale Feeder. You must ensure that you and anyone else who is going to operate, maintain or work around the Bale Feeder be familiar with the operating and maintenance procedures and related safety information contained in this manual.

Remember, YOU are the key to safety. Good safety practices not only protect you but also the people around you. Make these practices a working part of your safety program. Most accidents can be prevented. Do not risk injury or death by ignoring good safety practices. Review the operating instructions for this header at least once a year per OSHA regulations 1928.57. Know the meaning and location of each decal before operating the BF5000.

Watch for this symbol in this manual and on the Bale Feeder:



1. Keep a first aid kit in the cab for emergencies and know how to use it.
2. Do not allow any one to ride on the Bale Feeder while it is in motion.
3. Clear the area of bystanders, especially small children before starting the Bale Feeder.
4. Do not allow anyone to operate the Bale Feeder who has not been instructed in how to use the machine.
5. All operators should familiarize themselves with the safety section in the operator's manual.
6. Some pictures or illustrations may not show protective shields in place. Make certain that all protective shields are in place before operating the machines.

Operating and Maintenance Safety

1. DANGER, DO NOT stand around or near the Discharge or bed area. Objects thrown from the beaters may cause death or serious injury
2. Hydraulic leaks can penetrate the skin causing serious injuries. Small leaks can be invisible and are the most dangerous. Use some object, like cardboard, to find the leak. Do not use your hand.

Hydraulic Safety

Ensure that all the pressure is released from the hydraulic lines before repairing.
Replace or repair damaged hoses immediately.



WARNING



When checking for oil leaks use a piece of cardboard; DO NOT use your hand:

Escaping fluid under pressure can penetrate the skin causing serious injury.
Avoid the hazard by relieving pressure before disconnecting hydraulic of other lines.
Tighten all line connections before applying pressure.
Protect hands and body from high-pressure fluids.

If an accident occurs, see a doctor immediately. Any fluid injected into the skin must be surgically removed within a few hours or gangrene may result. Doctors unfamiliar with this type of injury should reference a knowledgeable medical source. Failure to comply could result in death or serious injury.

DO NOT weld on or near rotating parts. Welding close to rotating parts will cause warping and will challenge the structural integrity.

DO NOT weld on or near rotating parts. Welding close to rotating parts may cause warping thus creating high stress loads for moving or rotating parts.

DO NOT weld on wheels. Welding on wheels may cause high stress and wheel failure.

DO NOT weld on wheels with a mounted tire, Welding on wheels with a mounted tire may cause tire to burst, causing serious injury or death.

Decals

The following safety decals have been placed on your machine in the areas indicated. They are intended for personal safety and or those working with you. Please take this manual and walk around your machine to note the content and location of these warning sign. Review these warning signs and the operating instruction detailed in this manual with your machine operators. Keep the decals legible, if they are not, obtain replacements from your authorized dealer. The decal replacement numbers are listed with each decal.

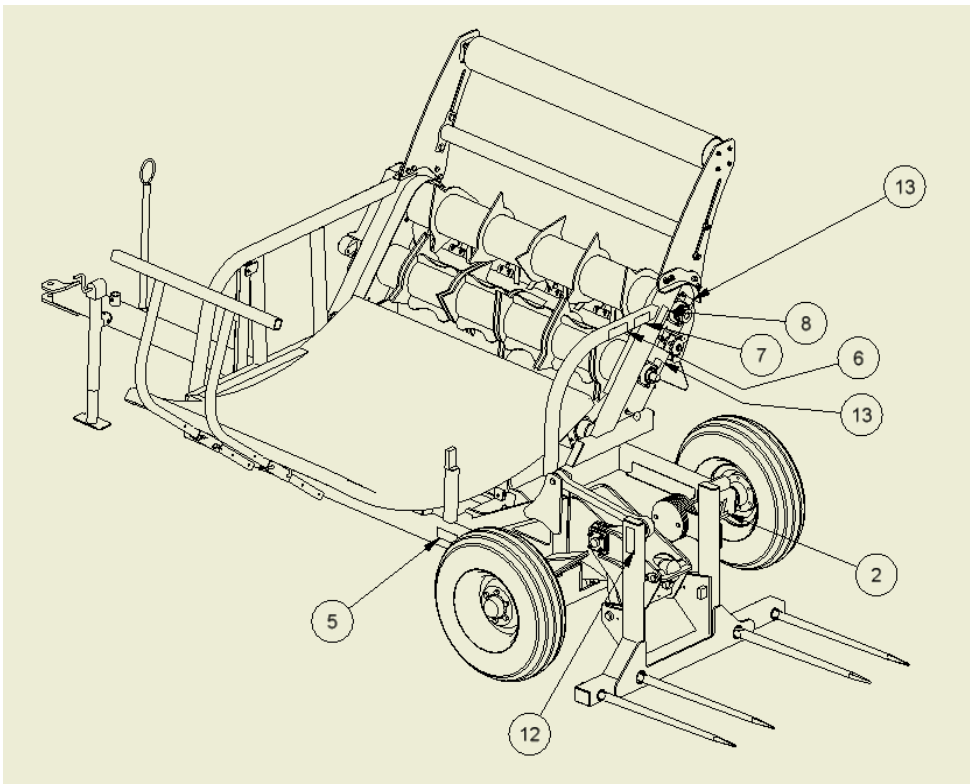

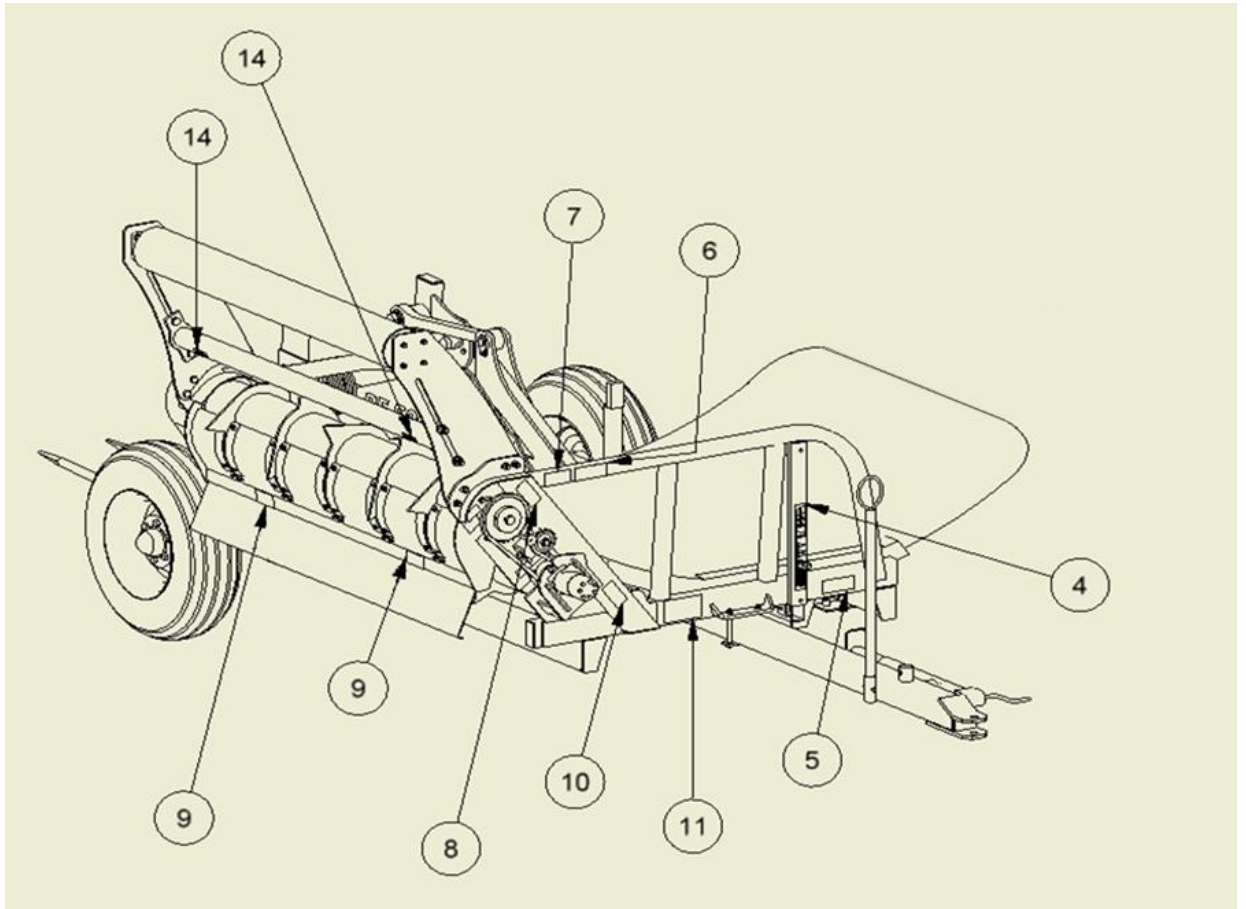
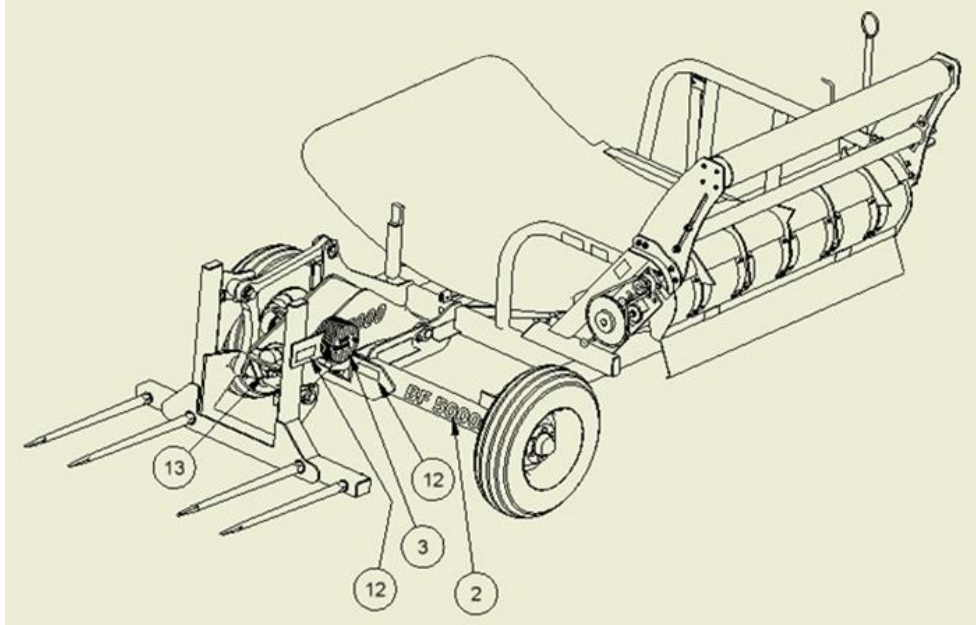

Decals

BF 5000SL

Decal 2- BF-5000-162



Decal 3- PP-00525



Decal 4- PP-00547

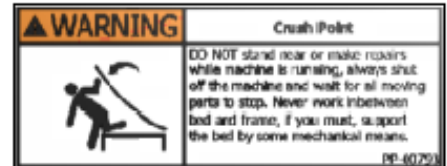

Decal 5- PP-00793

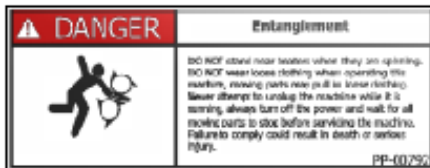

Decal 6- PP-00792



Decal 7- PP-00790

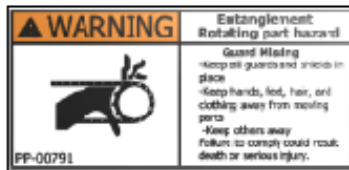

Decal 8- PP-00791

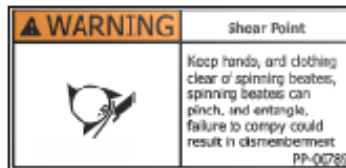

Decal 9- PP-00789



Decal 10- PP-00788

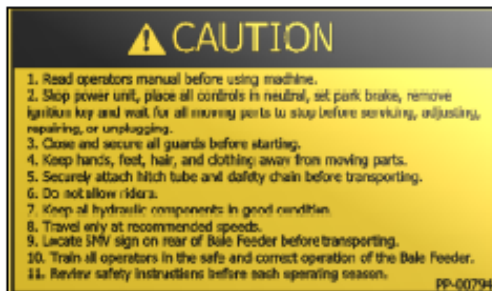

Decal 11- PP-00794

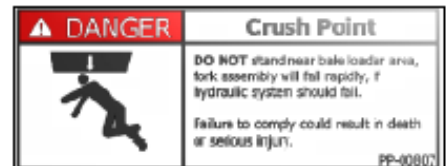

Decal 12- PP-00807

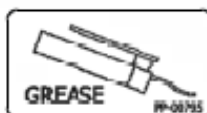

Decal 13- PP-00795



Decal 14- PP-00811

Decals

Item	Qty	Part #	Description
2	1	PP-00525	Keep Clear Decal
3	1	PP-00547	Lift Platform Decal
4	2	PP-00793	Crush Point (Warning) Decal
5	2	PP-00792	Entanglement (Danger) Decal
6	2	PP-00790	Thrown Objects Decal
7	2	PP-00791	Entanglement (Warning) Decal
8	2	PP-00789	Shear Point Decal
9	1	PP-00788	High Pressure Decal
10	1	PP-00794	Read Manual Decal
11	3	PP-00807	Crush Point (Danger) Decal
12	6	PP-00795	Grease Decal
13	2	PP-00811	Detach From Bumper Decal

Items you will find with your Tube-line Self Loading Bale Feeder

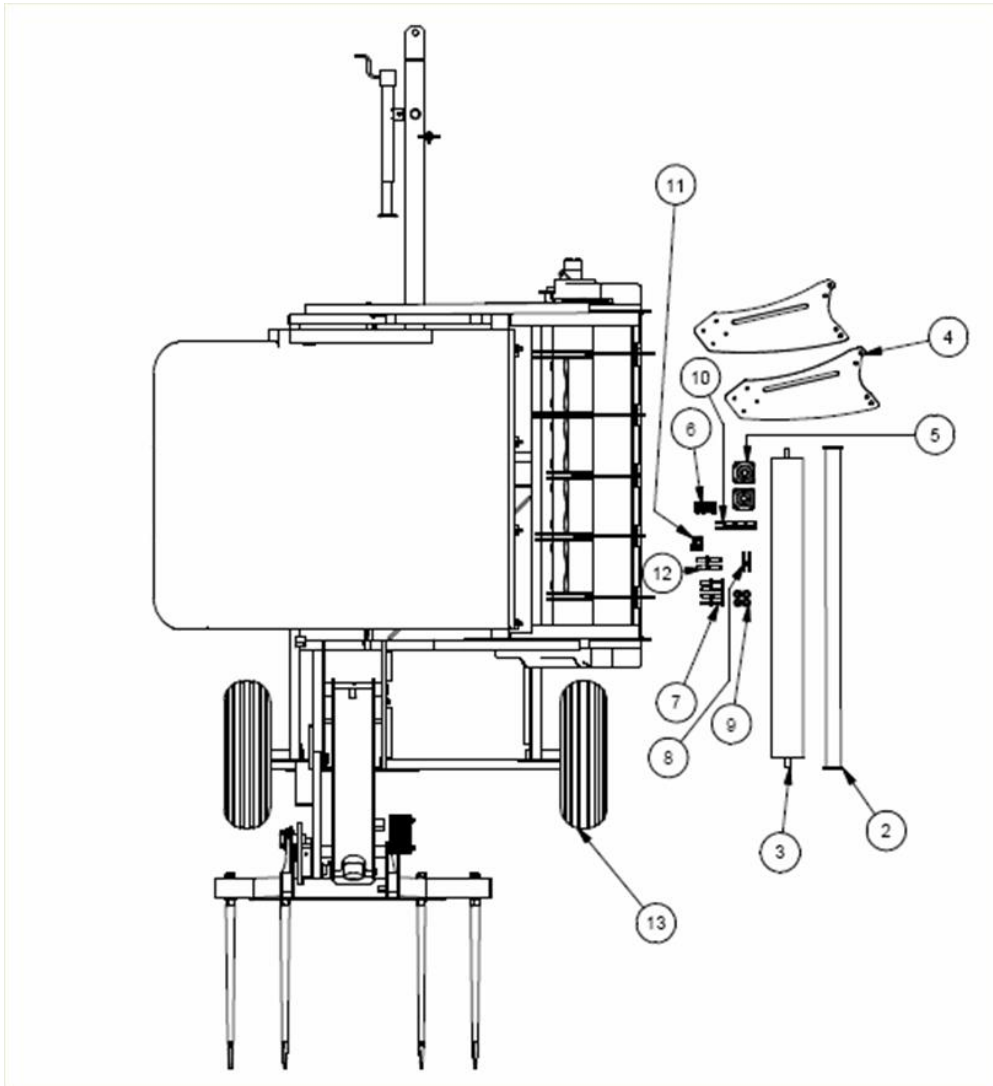

Item	Qty	Part #	Description
2	1	BF-5000-a19	Second Roller
3	1	BF-5000-a20	Bumper Roller
4	2	BF-5000-260	Bumper Plate
5	2	PP-00655	F206, 1.125 (ID) Bearing
6	8	Obtain Locally	LN .625 Lock Nut
7	8	Obtain Locally	HB .625 x 1.75 Hex Bolt
8	8	Obtain Locally	LN .438 Lock Nut
9	4	Obtain Locally	FW .75 Flat Washer
10	8	Obtain Locally	HB .438 x 1.5 Hex Bolt
11	4	Obtain Locally	LN .75 Lock Nut
12	4	Obtain Locally	HB .75 x 2 Hex Bolt
13	1	BF-5000-SL-00	Complete Assembly

Self Loading Assembly

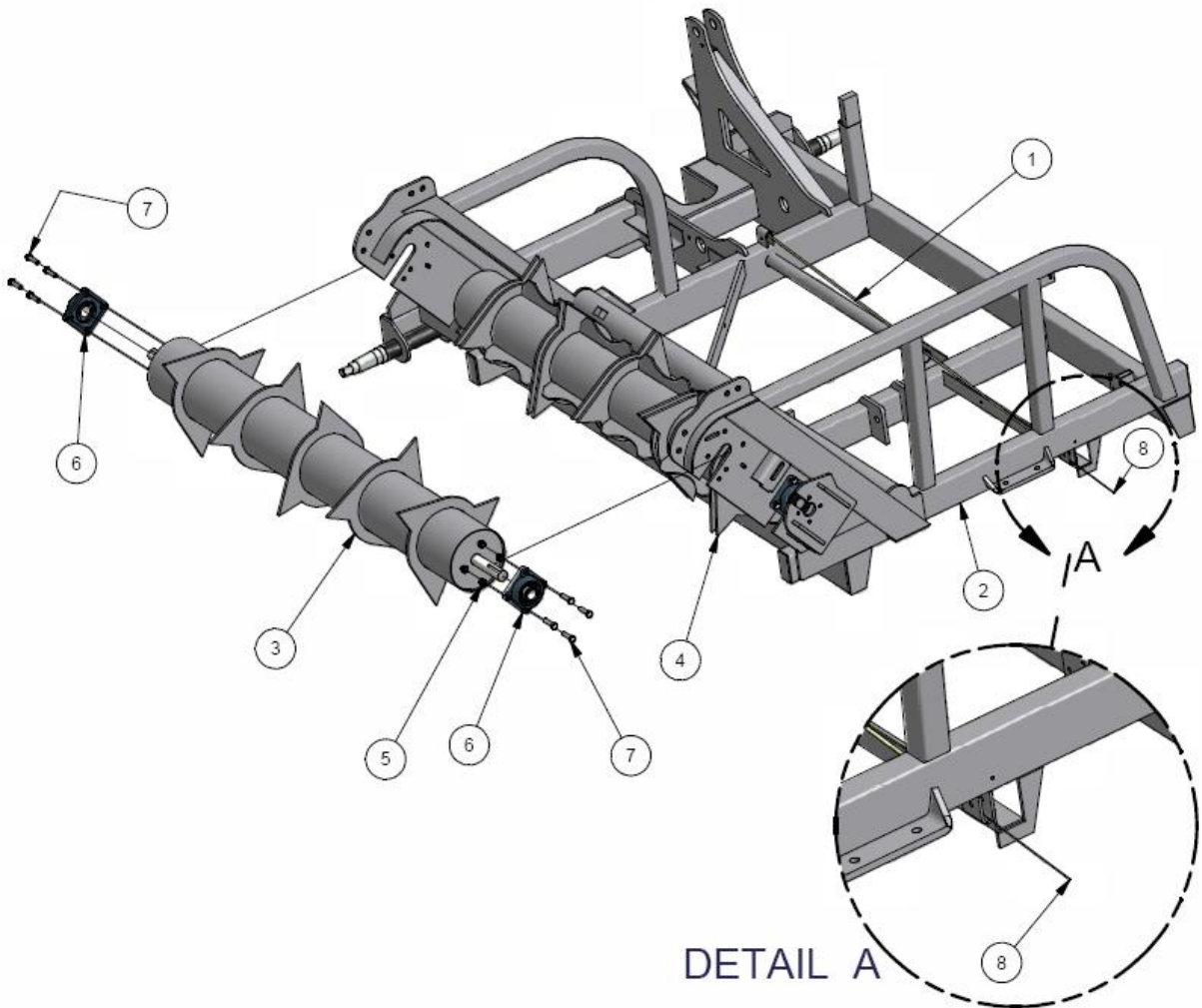

Item	Qty	Part #	Description
1	1	BF-5000-325	Cord Protector
2	1	BF-5000-SL-00	Frame Assembly
3	1	BF-5000-a01	Top Drum Assembly
4	1	BF-5000-a02	Bottom Drum Assembly
5	16	Obtain Locally	LN .5 Lock Nut
6	4	PP-00309	F207-22 Pillow Block
7	16	Obtain Locally	HB .5 x 1.75 Hex Bolt
8	1	PP-00580	1/8" Galv. Braided Wire Cable (96")

Self Loading Assembly

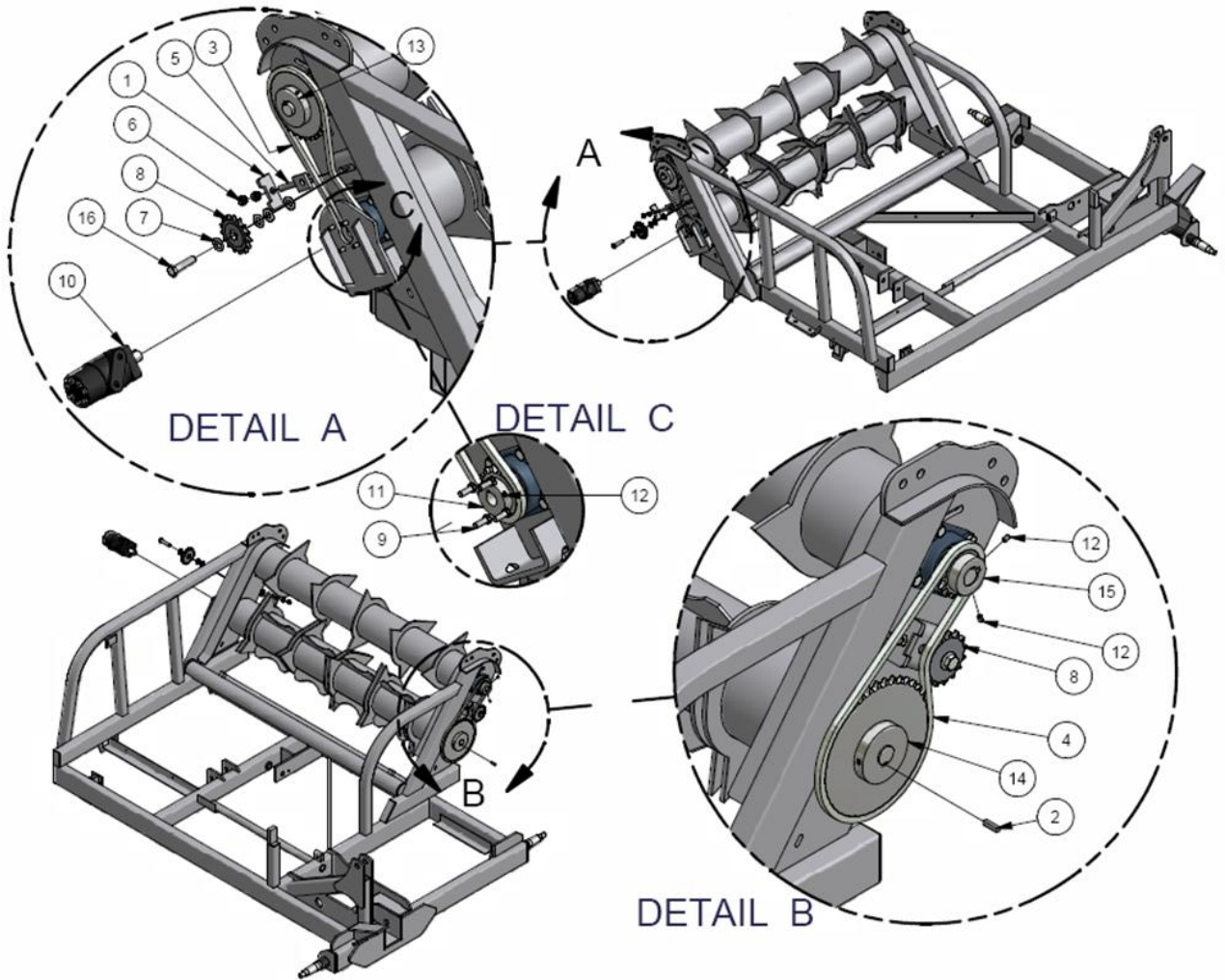

Item	Qty	Part #	Description
1	2	BF-5000-246	Chain Tightener Bracket
2	3	BF-5000-253	Key
3	1	BF-5000-254	60 series-28.5 Links
4	1	BF-5000-255	60 series-32 Links
5	2	BF-5000-a17	Slide Assembly
6	4	Obtain Locally	HN .5 Hex Nut
7	8	Obtain Locally	FW .625 Flat Washer
8	2	PP-00060	60-15 Idler Sprocket
9	4	Obtain Locally	HB .375 x 1 Hex Bolt
10	1	PP-00202	HMD Motor MLHPQ400C4B
11	1	PP-00420	60-15 X ID 1" Drive Sprocket
12	8	Obtain Locally	SS .313 x .5 Set Screw
13	1	PP-00521	60-30 Drive Sprocket
14	1	PP-00522	60-42 Drive Sprocket
15	1	PP-00523	60-15 Drive Sprocket
16	2	Obtain Locally	HB .625 x 2.625 Hex Bolt

Self Loading Assembly

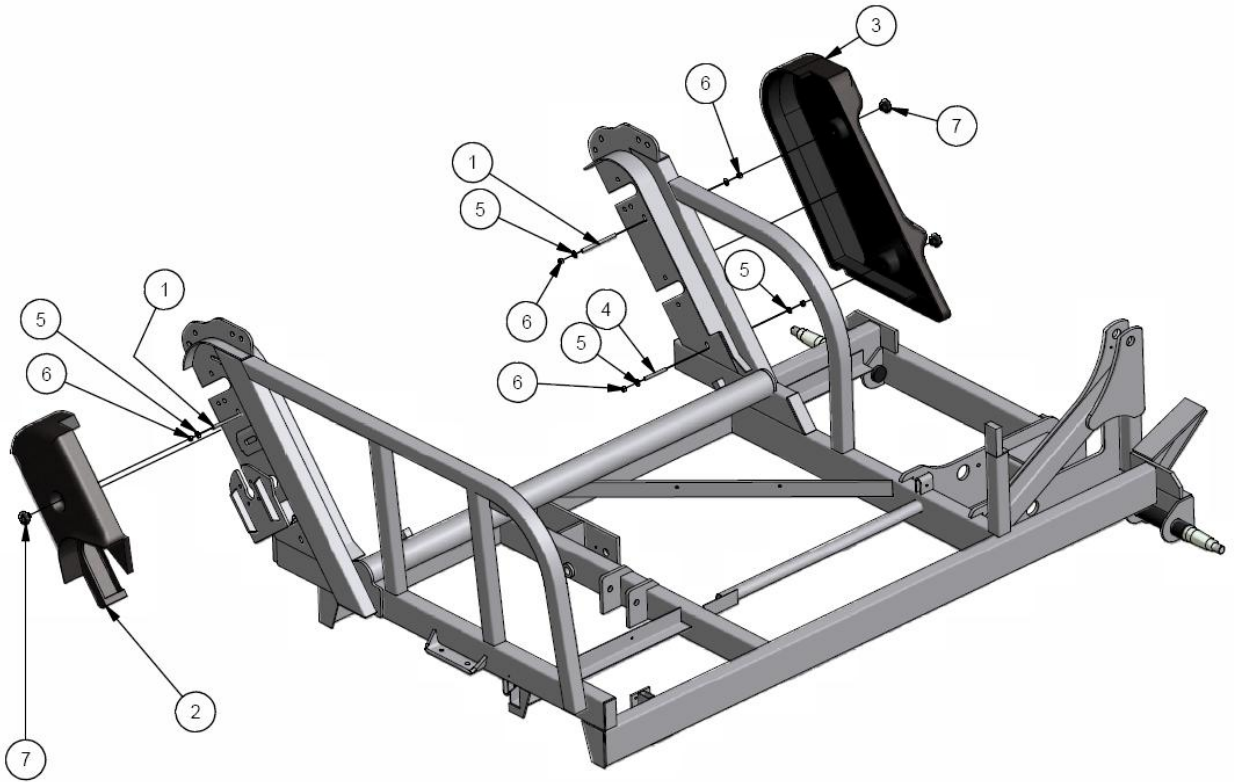

Item	Qty	Part #	Description
1	2	BF-5000-106	Tightener Rod
2	1	BF-5000-108	Bale Feeder Small Guard
3	1	BF-5000-109	Bale Feeder Large Guard
4	1	BF-5000-250	Bottom Tightener Rod
5	6	Obtain Locally	FW .375 Flat Washer
6	6	Obtain Locally	HN .375 Hex Nut
7	3	PP-00590	Hand Wheel

Self Loading Assembly

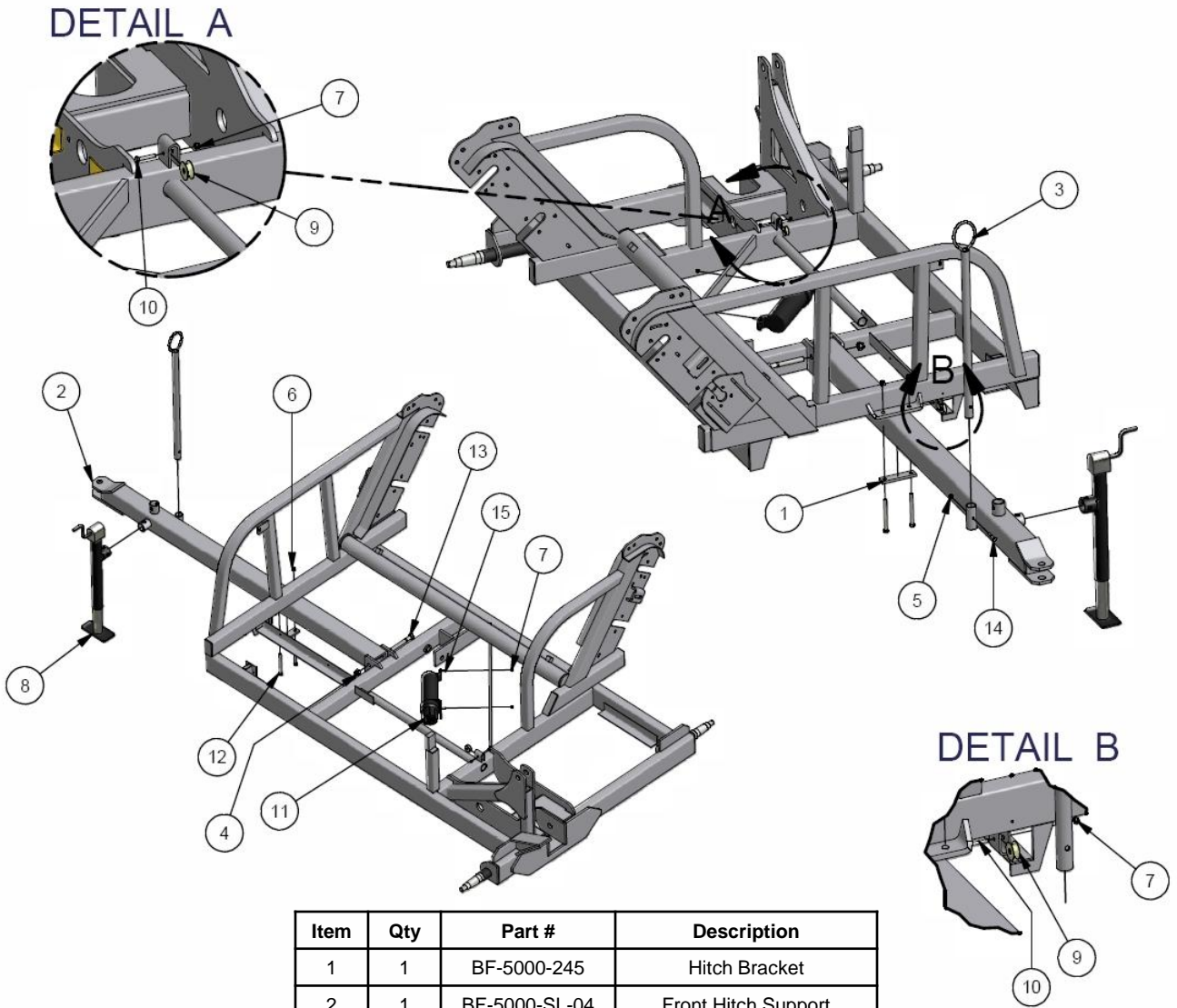

Item	Qty	Part #	Description
1	1	BF-5000-245	Hitch Bracket
2	1	BF-5000-SL-04	Front Hitch Support
3	1	BF-5000-SL-11	Hose Bracket
4	1	Obtain Locally	LN .75 Lock Nut
5	1	Obtain Locally	LN .375 Lock Nut
6	2	Obtain Locally	LN .5 Lock Nut
7	4	Obtain Locally	LN .25 Lock Nut
8	1	PP-00302	15' Jack
9	2	PP-00423	Rope Pulley
10	2	Obtain Locally	HB .25 x 1.5 Hex Bolt
11	1	PP-00535	Manual Holder
12	2	Obtain Locally	HB .5 x 5.5 Hex Bolt
13	1	Obtain Locally	HB .75 x 6 Hex Bolt
14	1	Obtain Locally	HB .375 x 1.25 Hex Bolt
15	2	Obtain Locally	HB .25 x 1.25 Hex Bolt

Self Loading Assembly

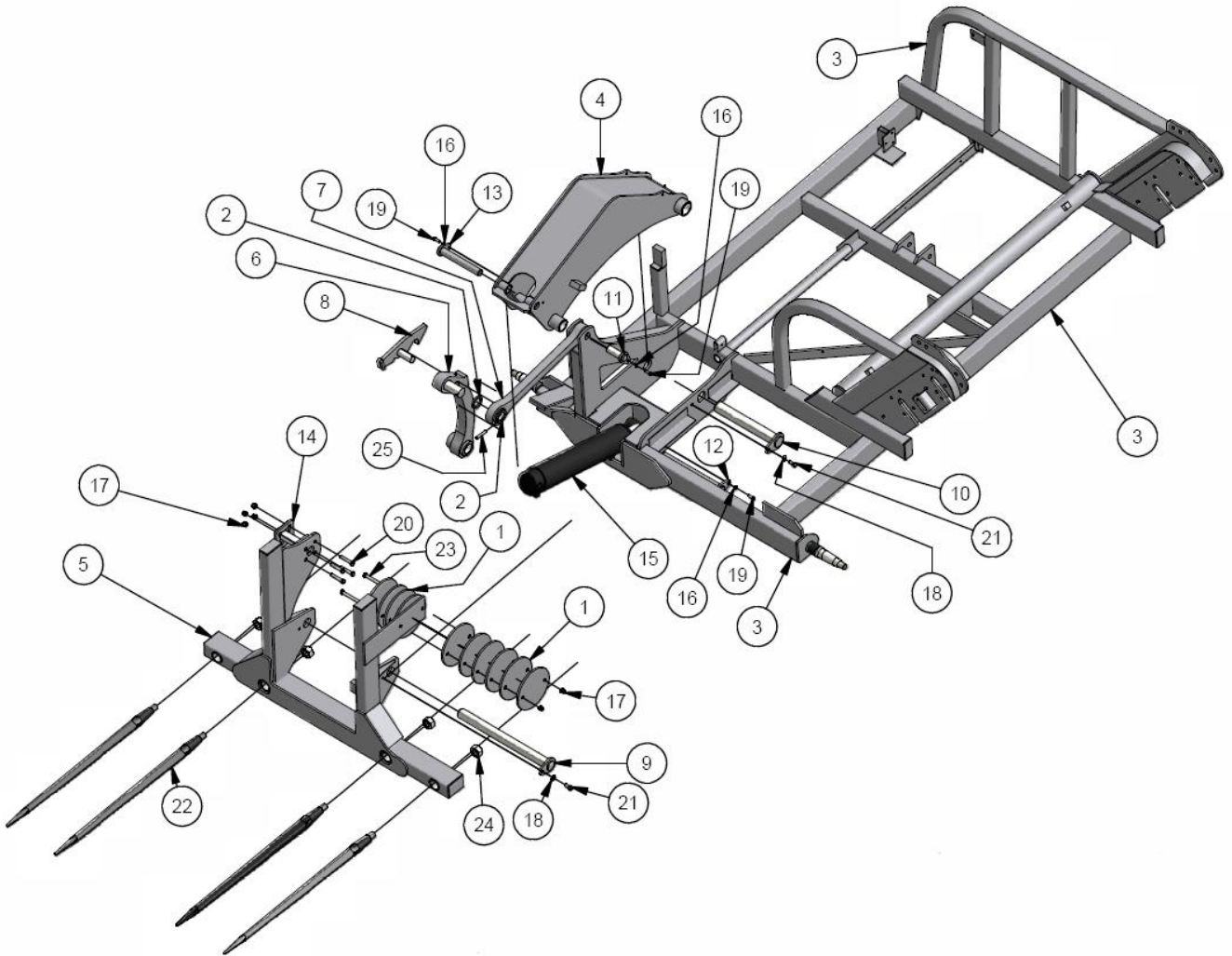

Item	Qty	Part #	Description	Item	Qty	Part #	Description
1	10	BF-5000-175	Weight	14	1	BF-5000-a13	Latch Pin Assembly
2	2	BF-5000-257	Spacer	15	1	CY-40019-01-00	4" Bore x 19" Stroke Cylinder
3	1	BF-5000-SL-01	Frame Assembly	16	3	PP-00008	3/8" Flat Washer
4	1	BF-5000-SL-02	Loader Arm Assembly	17	6	PP-00014	1/2-13 UNC Lock Nut
5	1	BF-5000-SL-03	Fork Frame Assembly	18	2	PP-00016	1/2 Flat Washer
6	1	BF-5000-SL-08	Arm Assembly	19	3	Obtain Locally	HB.375 x 1 Hex Bolt
7	1	BF-5000-SL-09	Top Loader Arm	20	4	Obtain Locally	HB .5 x 2.5 Hex Bolt
8	1	BF-5000-SL-10	Loader Hook	21	2	Obtain Locally	HB .5 x 1 Hex Bolt
9	1	BF-5000-a07	Fork Pin	22	4	PP-00546	Fork Spear (32")
10	1	BF-5000-a08	Loader Arm Pin	23	2	Obtain Locally	HB .5 x 5 Hex Bolt
11	1	BF-5000-a09	Top Loader Arm Pin	24	4	Obtain Locally	HN M30 x 3.5 Hex Nut
12	1	BF-5000-a11	Loader Cyl. Bottom Pin	25	1	PP-00648	Roll Pin
13	1	BF-5000-a12	Loader Cyl. Top Pin		1	SK40019	Cylinder Seal Kit

Self Loading Assembly

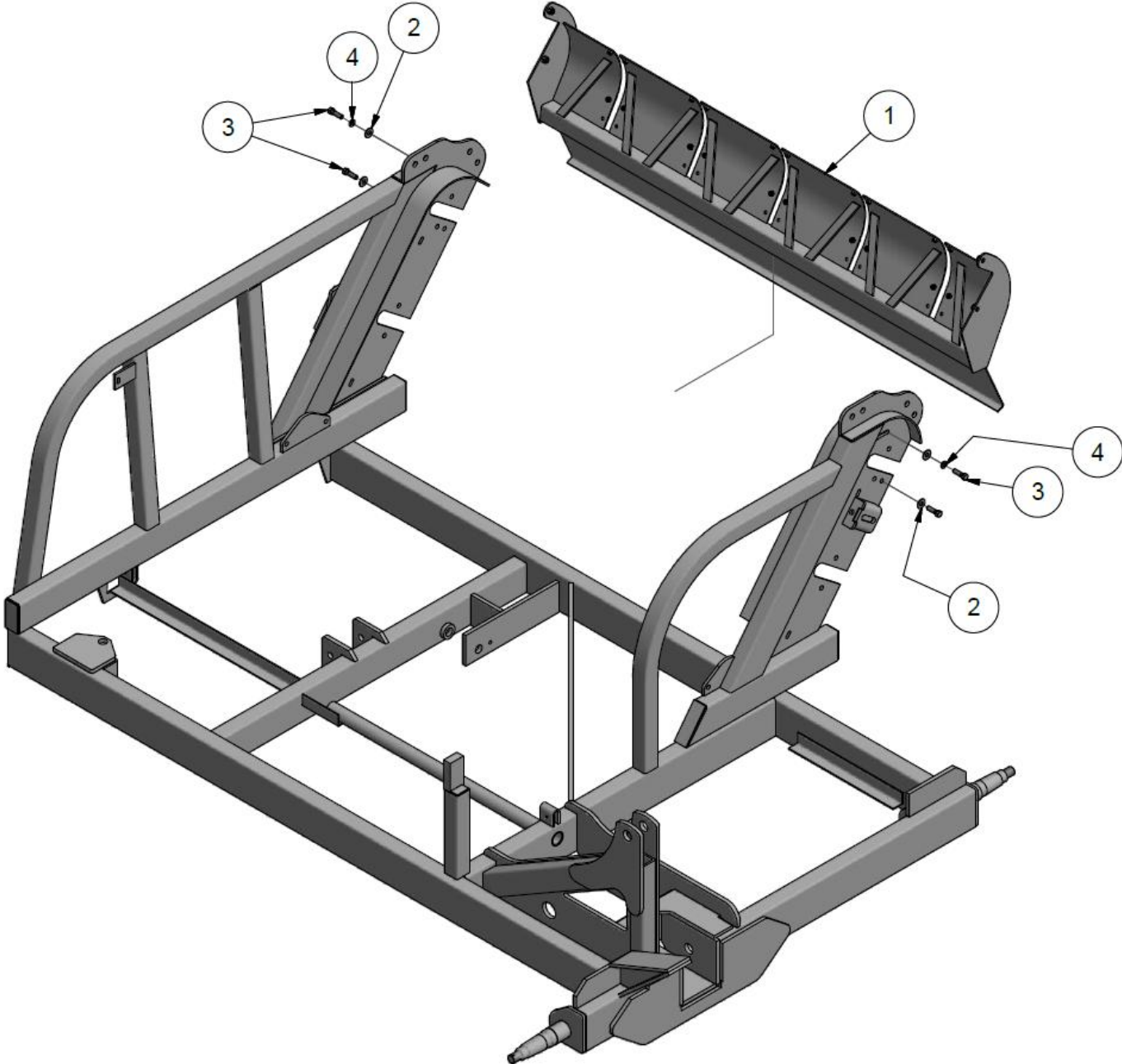

Item	Qty	Part #	Description
1	1	BF-5000-a03	Large Wiper Assembly
2	4	Obtain Locally	FW .438 Flat Washer
3	4	Obtain Locally	HB .438 x 1.5 Hex Bolt
4	2	Obtain Locally	FW .438 Lock Washer

Self Loading Assembly

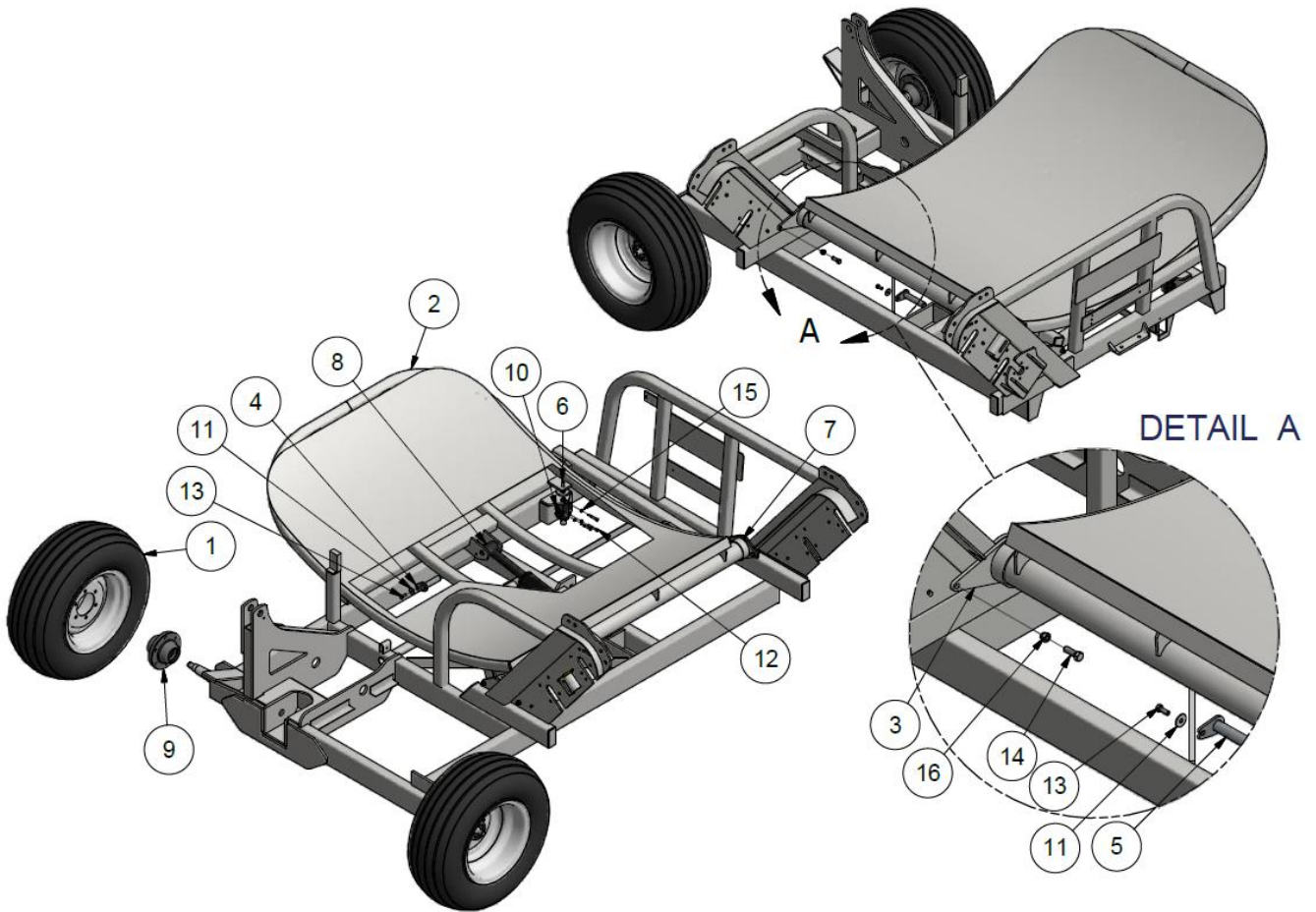

Item	Qty	Part #	Description
1	2	WHE 11LX15X8	Tire
2	1	BF-5000-06b	Bed Assembly
3	1	BF-5000-22b	Pivot Tab
4	1	BF-5000-a14	Bed Cylinder Pin
5	1	BF-5000-a15	Frame Cylinder Pin
6	1	BF-5000-a16	Stop Pad
7	1	BF-5000-a21b(-22b)	Pivot Tab
8	1	CY-30014-01-00	3' Bore x 14" Stroke Cylinder
9	2	HUB 6000	6000lbs Hub Assembly
10	1	PP-00566	Diverter Valve
11	2	Obtain Locally	FW .375
12	3	Obtain Locally	HB .25 X 2.25 Hex Bolt
13	2	Obtain Locally	HB .375 X 1 Hex Bolt
14	4	Obtain Locally	HB .5 X 1.5 Hex Bolt
15	3	Obtain Locally	LN .25 Lock Nut
16	4	Obtain Locally	LN .5 Lock Nut
	1	SK30014	Cylinder Seal Kit

Self Loading Assembly

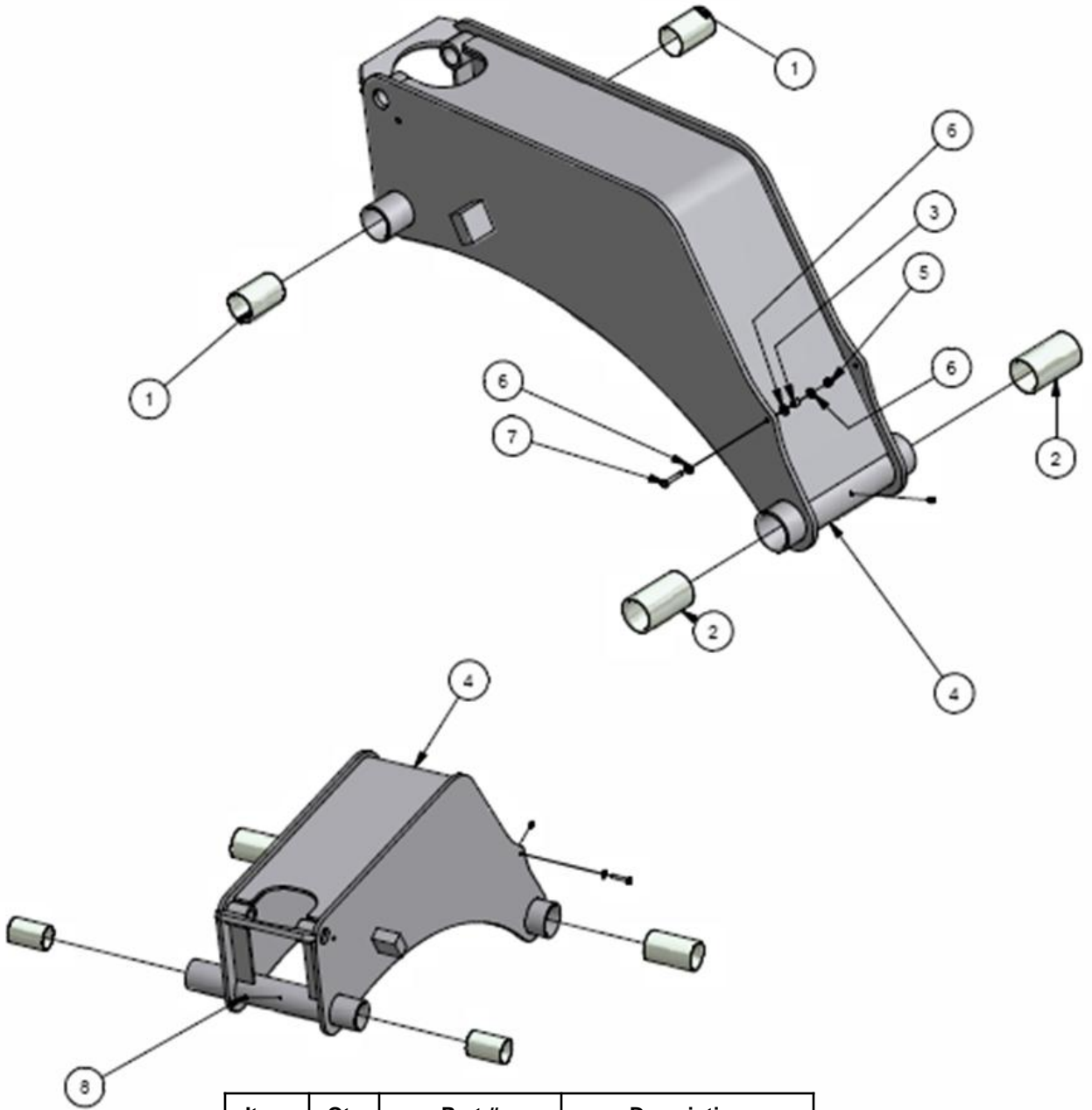

Item	Qty	Part #	Description
1	2	BF-5000-239	Fork Bushing
2	2	BF-5000-240	Arm Pivot Bushing
3	1	BF-5000-269	Cable Spacer
4	1	BF-5000-SL-02	Loader Arm Assembly
5	1	Obtain Locally	LN .25 Lock Nut
6	3	Obtain Locally	FW .25 Flat Washer
7	1	Obtain Locally	HB .25 x 1.5 Hex Bolt
8	2	Obtain Locally	.188 Knock in Greaser

Self Loading Assembly

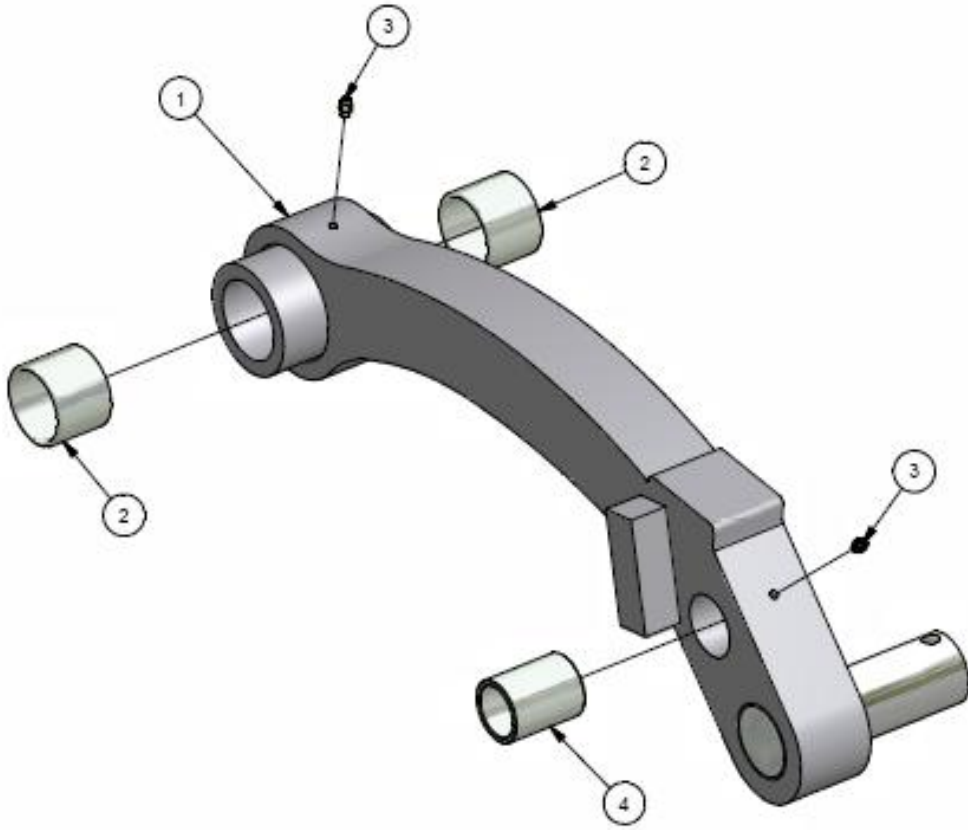

Item	Qty	Part #	Description
1	1	BF-5000-SL-08	Arm Assembly
2	2	BF-5000-241	Loader Arm Bushing
3	2	Obtain Locally	.188 Knock in Greaser
4	1	BF-5000-242	Latch Bushing

Self Loading Assembly

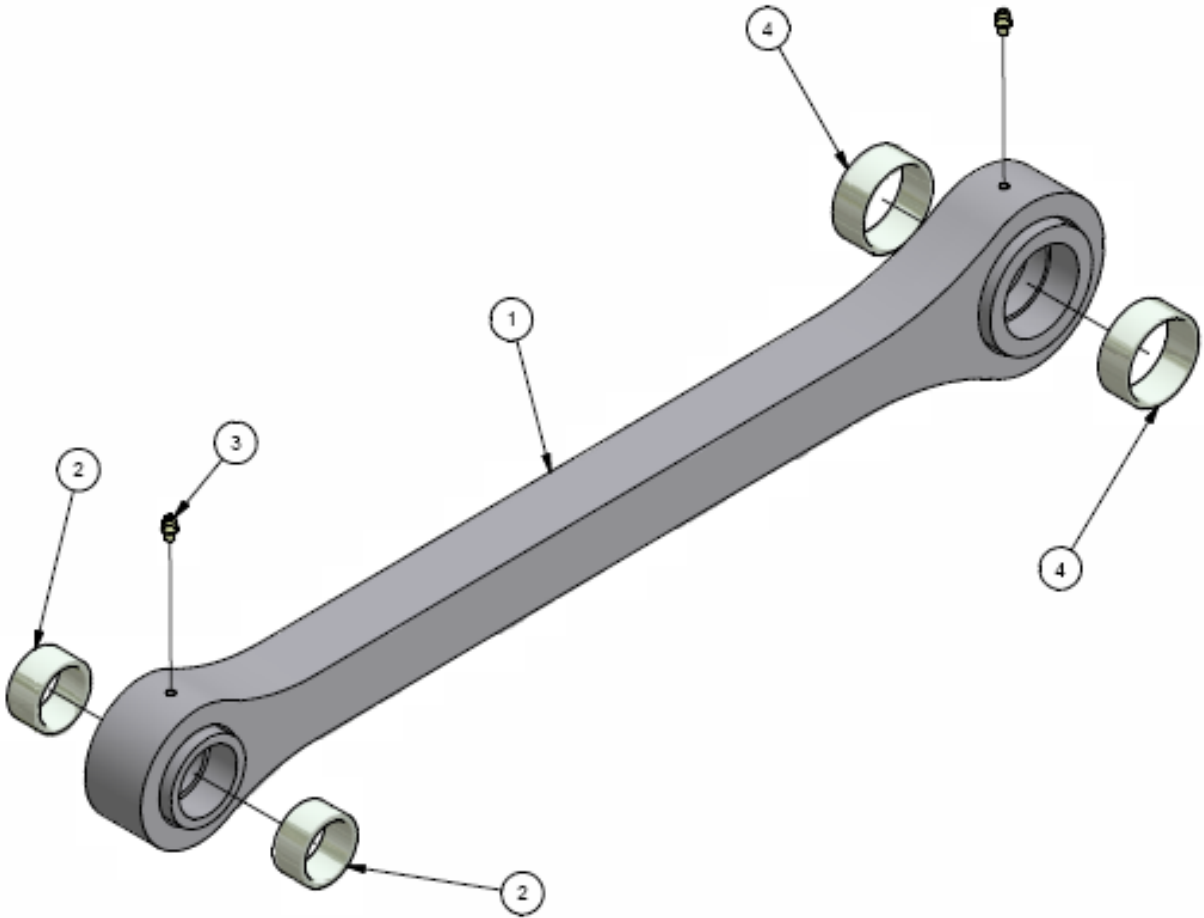

Item	Qty	Part #	Description
1	1	BF-5000-SL-09	Top Loader arm
2	2	BF-5000-243	Small Loader Arm Bushing
3	2	Obtain Locally	.188 Knock in Greaser
4	2	BF-5000-244	Large Loader Arm Bushing

Indicator Assembly

BF-5000-SL-05

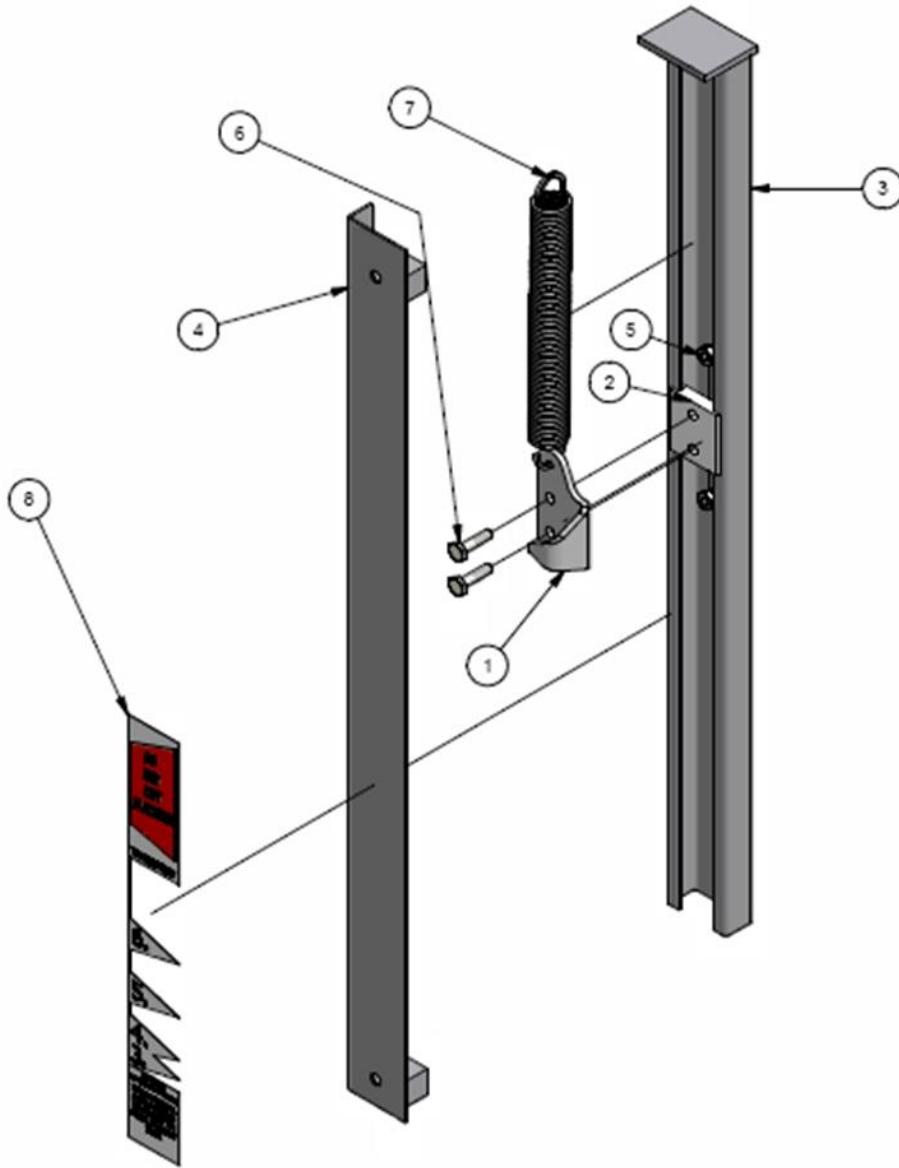

Item	Qty	Part #	Description
1	1	BF-5000-182	Indicator
2	1	BF-5000-183	Indicator Slider
3	1	BF-5000-SL-06	Indicator Assembly aa
4	1	BF-5000-SL-07	Indicator Assembly bb
5	2	Obtain Locally	LN .25 Lock Nut
6	2	Obtain Locally	HB .25 x 1 Hex Bolt
7	1	PP-00491	Spring
8	1	PP-00547	Decal - Lift Platform

Wiper Assembly

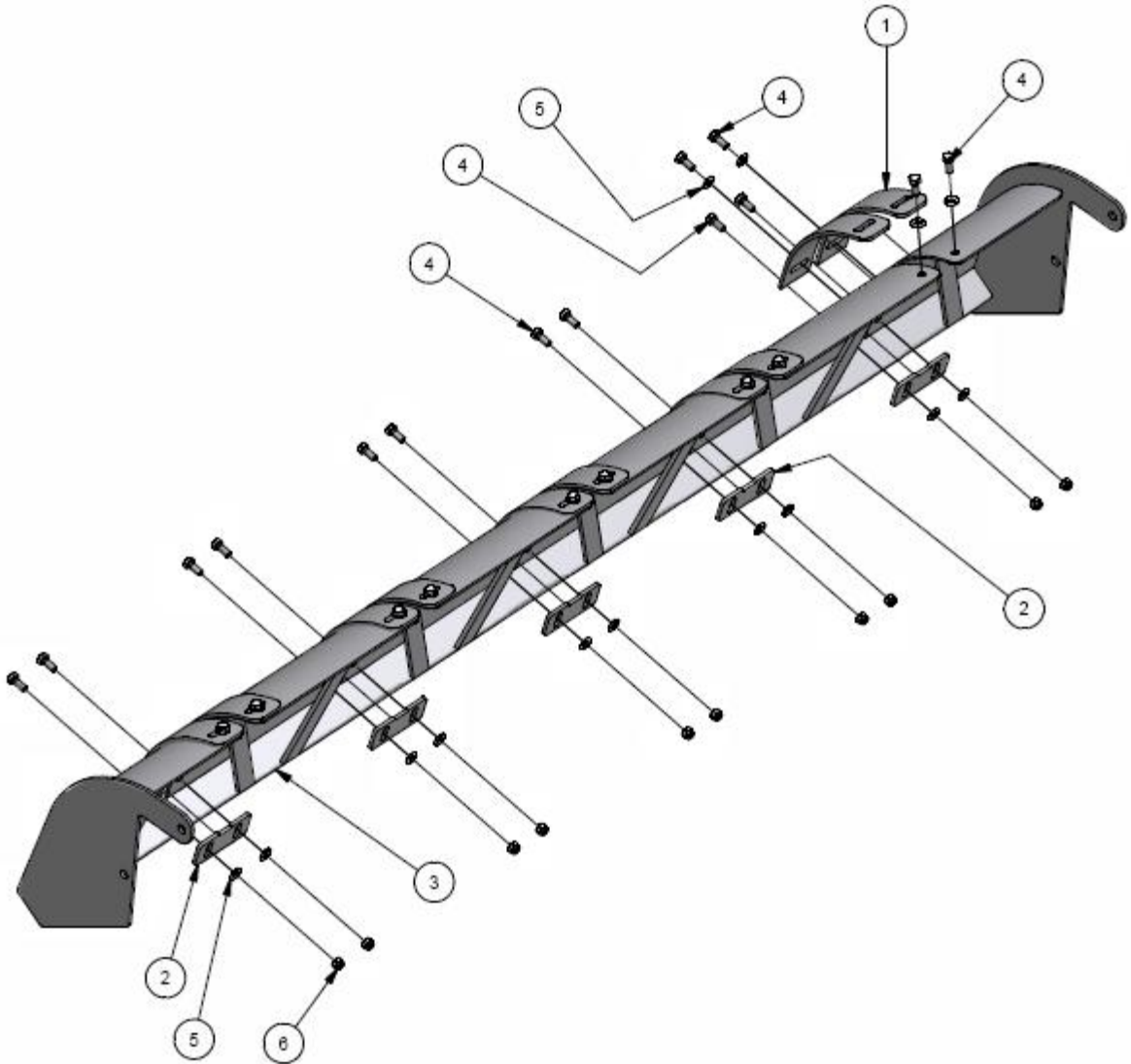

Item	Qty	Part #	Description
1	10	BF-5000-100	Slot Opening Guide
2	5	BF-5000-101	Inside Bracket Guide
3	1	BF-5000-a18	Small Wiper Assembly
4	30	Obtain Locally	HB .313 x .75 Hex Bolt
5	30	Obtain Locally	FW .313 Flat Washer
6	30	Obtain Locally	LN .313 Lock Nut

Bumper Assembly

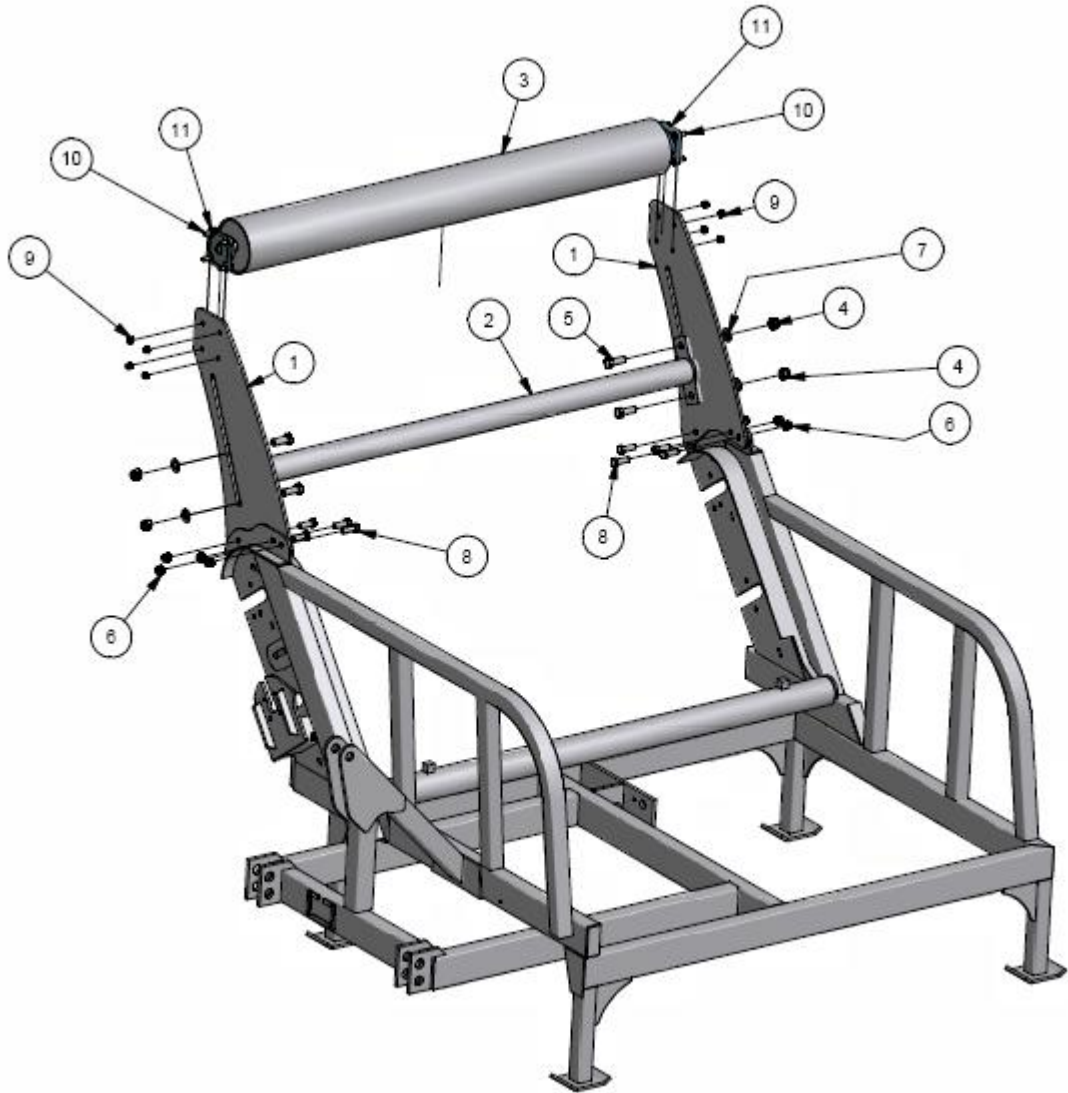

Item	Qty	Part #	Description
1	2	BF-5000-260	Bumper Plate
2	1	BF-5000-a19	Second Roller
3	1	BF-5000-a20	Bumper Roller
4	4	Obtain Locally	LN .75 Lock Nut
5	4	Obtain Locally	HB .75 x 2 Hex Bolt
6	8	Obtain Locally	LN .625 Lock Nut
7	4	Obtain Locally	FW .75 Flat Washer
8	8	Obtain Locally	HB .625 x 1.75 Hex Bolt
9	8	Obtain Locally	LN .438 Lock Nut
10	8	Obtain Locally	HB .438 x 1.5 Hex Bolt
11	2	PP-00655	F206 1.125 (ID) Bearing

6000lb Hub Assembly

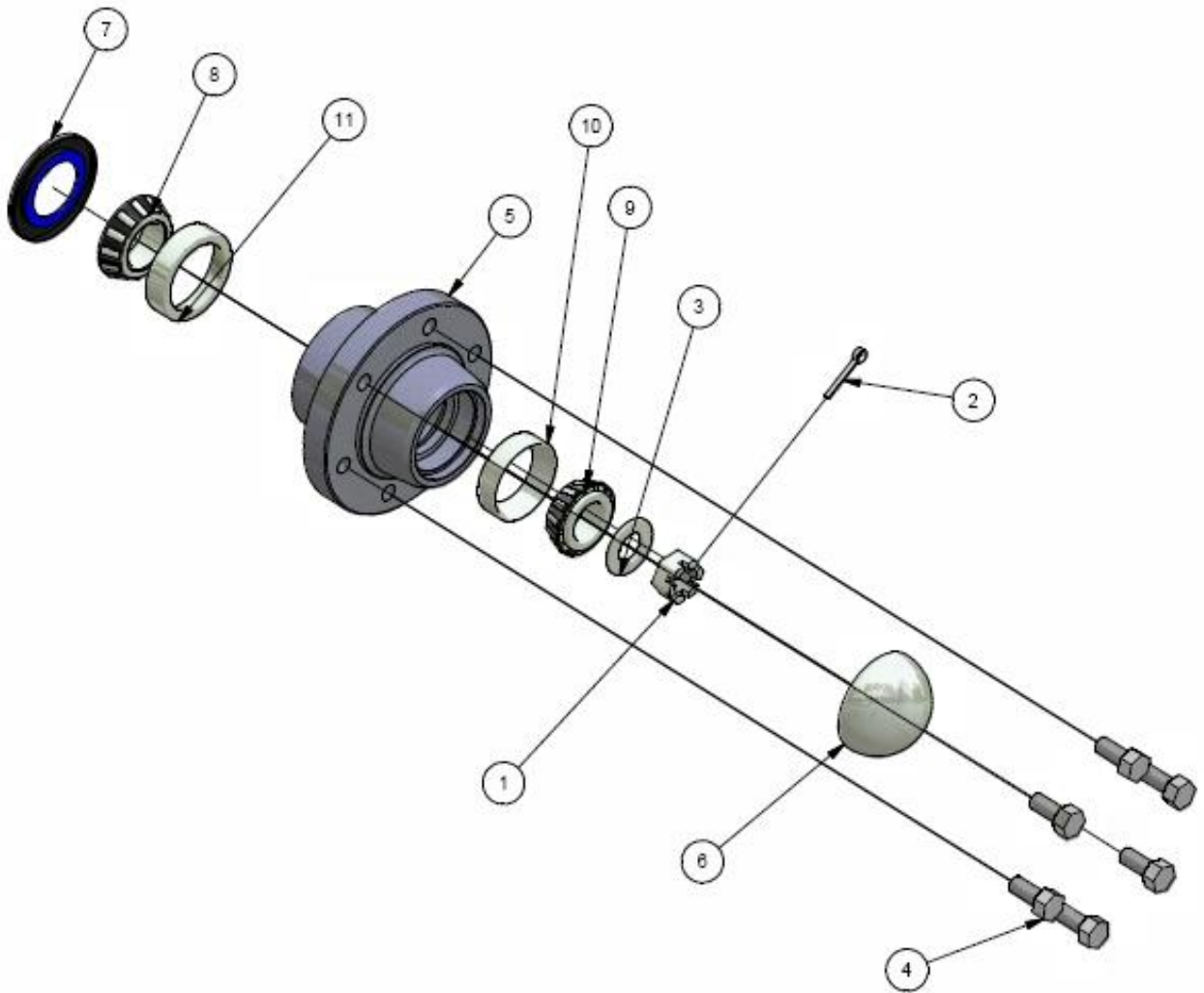

Item	Qty	Part #	Description
1	1	Obtain Locally	1-UNC Castle Nut
2	1	Obtain Locally	3/16 x 2 Brass Cotter Pin
3	1	Obtain Locally	1 Flat Washer
4	6	PP-00031	9/16-18 UNF x 1.75 Wheel Stud
5	1	PP-00527	6000lbs Hub
6	1	PP-00528	D-6000 Dust Cap
7	1	PP-00529	Grease Seal cr20148
8	1	PP-00530	Inner Cone
9	1	PP-00531	Outer Cone
10	1	PP-00532	Outer Cup
11	1	PP-00533	Inner Cup

Hydraulic Set-up

Item	Qty	Part #	Description
10	1	PP-00094	Coupling #6 F-JIC .375" Bore
11	1	28694	.375 Hydraulic Hose (185")
12	1	PP-00101	Coupling, #4 M-NPT .375 Bore

A



Item	Qty	Part #	Description
13	1	PP-00094	Coupling #6 F-JIC .375" Bore
14	1	28697	.375 Hydraulic Hose (146")
15	1	PP-00416	Coupling, #8 F-JIC .375 Bore

B



Item	Qty	Part #	Description
16	1	PP-00094	Coupling #6 F-JIC .375" Bore
17	1	28695	.375 Hydraulic Hose (120")
18	1	PP-00663	Coupling, #6 M-NPT .375 Bore

C



Item	Qty	Part #	Description
19	1	24114	.375 Hydraulic Hose (63")
20	2	PP-00416	Coupling #8 F-JIC .375" Bore

D



Item	Qty	Part #	Description
21	1	28696	.375 Hydraulic Hose (34")
22	1	PP-00416	Coupling #8 F-JIC .375" Bore
23	1	PP-00663	Coupling, #6 M-NPT .375 Bore

E



Item	Qty	Part #	Description
24	1	PP-00094	Coupling #6 F-JIC .375" Bore
25	1	27553	.375 Hydraulic Hose (116")
26	1	PP-00101	Coupling, #4 M-NPT .375 Bore

F



G

Item	Qty	Part #	Description
10	1	PP-00094	Coupling #6 F-JIC .375" Bore
11	1	28694	.375 Hydraulic Hose (120")
12	1	PP-00101	Coupling, #4 M-NPT .375 Bore

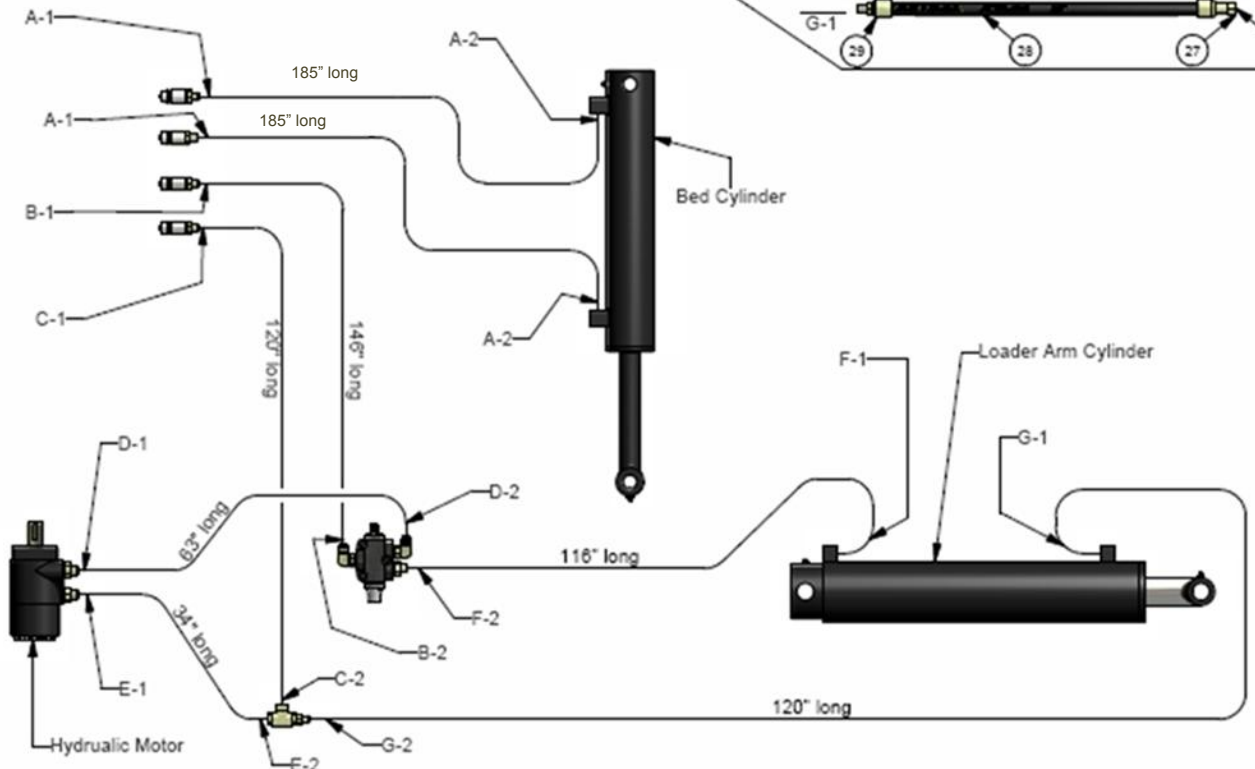

Hydraulic Set-up

Item	Qty	Part #	Description
1	1	CY-30014-01-00	Cylinder 3 x 14
2	1	CY-40019-01-00	Cylinder 4 x 19
3	1	PP-00104	Adapter #8 M-ORB/#6 M-JIC
4	1	PP-00166	Adapter #6 M-JIC/#6-NPT
5	1	PP-00202	Hydraulic Motor
6	2	PP-00410	Adapter #* M-JIC/ #10 M-ORB
7	1	PP-00511	Tee #6 F-NPT/#6 F-NPT
8	1	PP-00566	Diverter Valve
9	2	PP-00656	Adapter 90 #8 M-JIC/#8 M-ORB
11	4	PP-00662	Adapter #6 M-JIC/#8 M-NPT
12	4	PP-00661	Pioneer Male Coupler #8 F-NPT

Section 1 Assembly Information

NOTE: Assembly drawings are intended for use of replacement parts only, and not as assembly guide.

NOTE: Assembly drawings are placed in sequential order, as one would assemble, if desired part on drawing is shown already assembled you have gone to far, and must look at a previous drawing.

Section 2 General Information

Self Loading Bale Feeder

The Self Loading Bale Feeder unit consists of the main components listed below. The bale Feeder is powered by hydraulic pressure from a tractor. The hydraulic pressure from a tractor powers the hydraulic motor as well as both lift cylinders.

Principle Components

1. Frame
2. Beaters
3. Bed
4. Beater Motor
5. Bed Cylinder
6. Loader Arm Assembly
7. Fork Frame Assembly
8. Indicator

Self Loading Bale Feeder Terminology

Product Identification

The P.S.N stamped on the metal tag(1), is located on the front of the bale feeder.

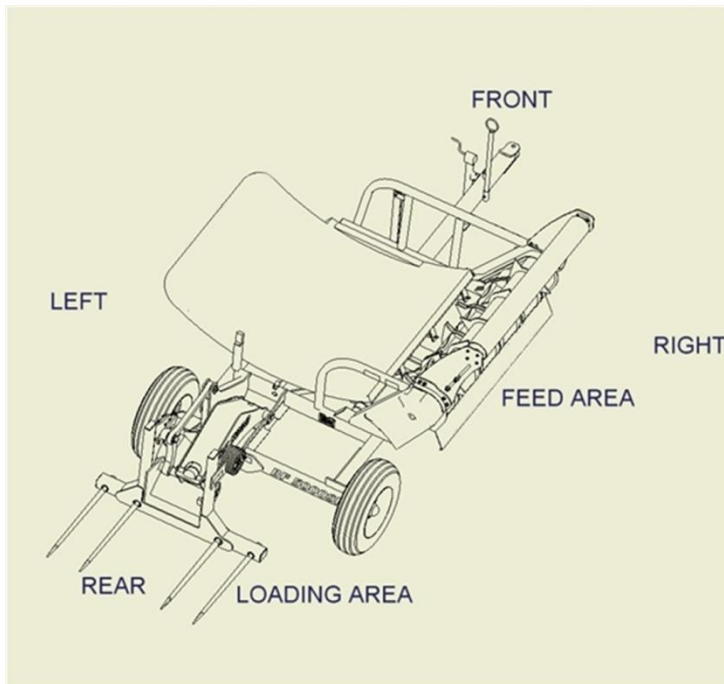
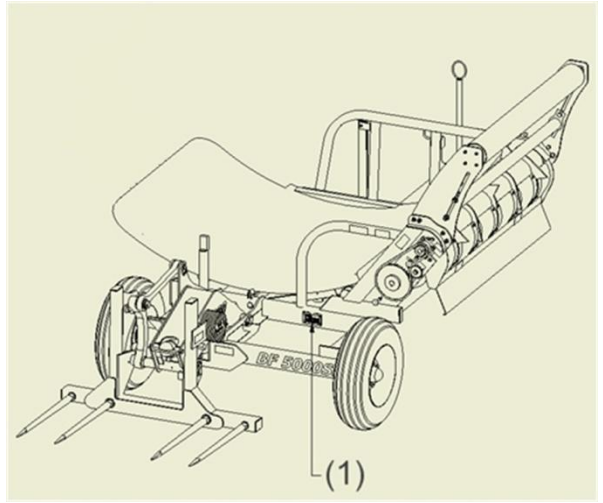
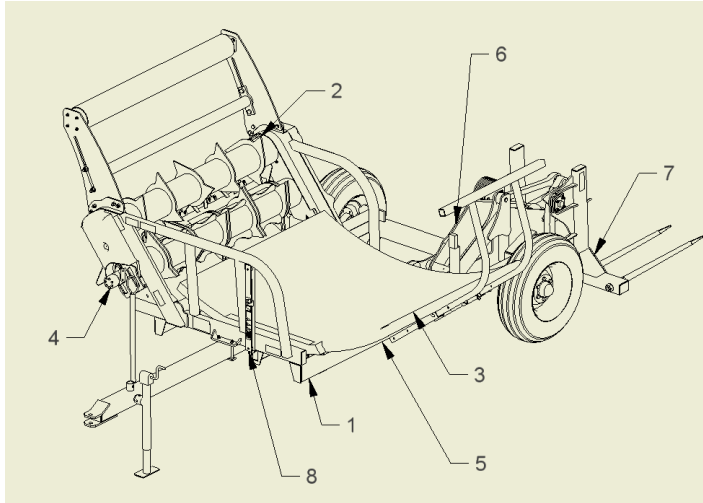

Serial# XX BFSL XXX

XX = year manufactured

BFSL = product identification

XXX = sequential numbering

Model # BF5000SL

BF5000 = BF5000

SL = Self Loading unit

Capacity

2 Bales = this unit can only contain 2 bales.

Weight

2700 = weight in pounds

Initial Setup

When you first receive the Tube-line Bale Feeder you will need to install the bumper bale rollers

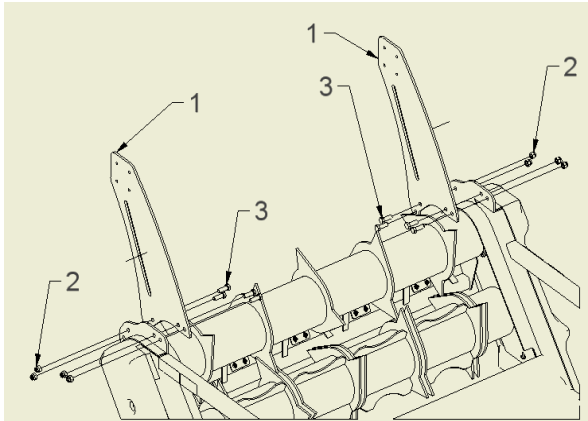

1. Secure bumper plate (1), using six 5/8-11 bolts(3), with 5/8-10 nuts(2) to the Tube-line Bale Feeder.

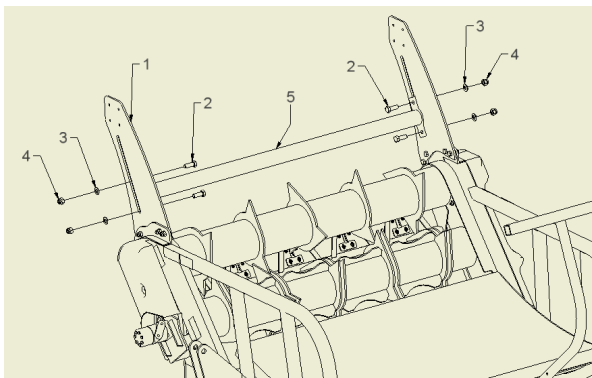

2. Secure second roller(5), with $\frac{3}{4}$ -10 bolts(2), $\frac{3}{4}$ flat washer(3) and $\frac{3}{4}$ -10 hex nut(3) to bumper plate(1).

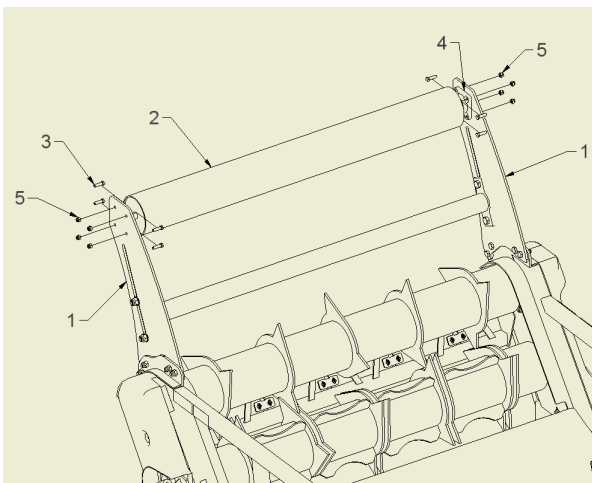

3. Secure bearing(4), and bumper roller(2), with 7/16-14 bolts(3), 7/16-14 hex nuts(5) to bumper plate (1).

Adjusting the BF5000 Beater Guide

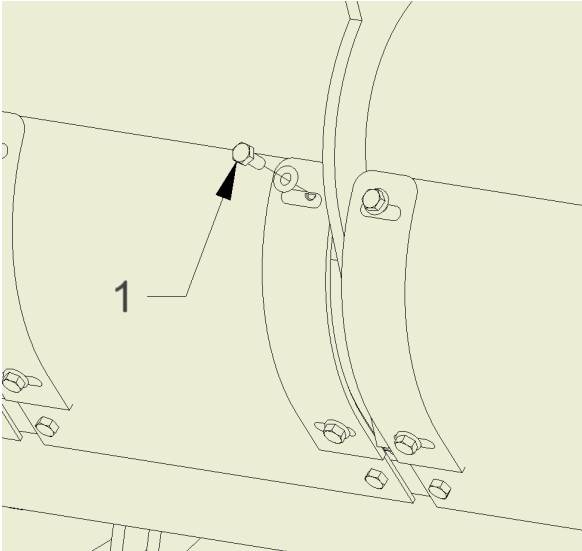

1. Loosen 5/16-18 bolt (1), and 5/16-18 nuts.

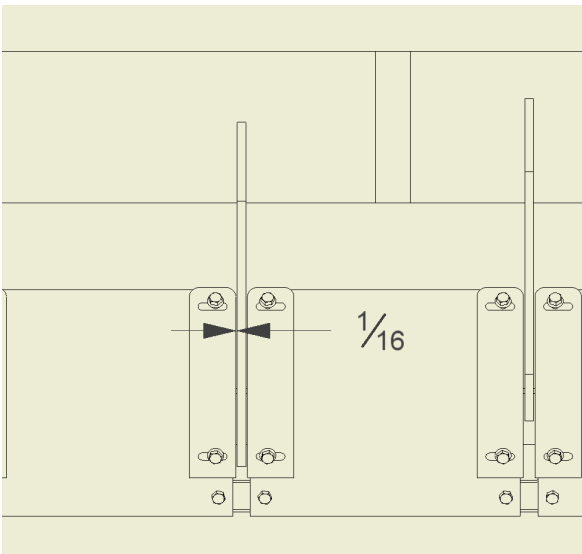

2. Adjust slot opening guide to 1/16" from beater and retighten fasteners.

Tube-line Bale Feeder Hook Up

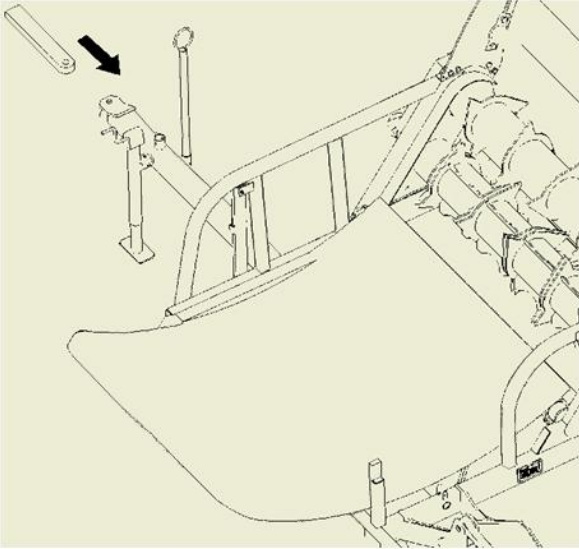

Make sure to apply the park brake before leaving the tractor. Death or serious injury could result if tractor moves.

1. Reverse tractor and align drawbar hole with BF5000 and insert pin.
2. Release jack(1), and secure in place(2).
3. Connect hydraulic lines.
4. Do a complete walk-around visual check to be sure there are no loose parts or components.
5. Do a visual check of all hoses to make sure they are securely tied so they will not pinch or drag during transporting.

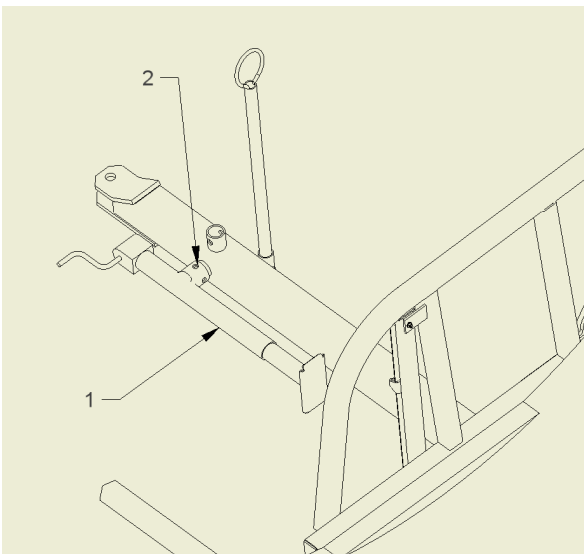

Check the hitch pins and safety chain periodically to make sure they are secure.

Transport Safety

1. Transport the Tube-line Bale Feeder with the SMV(Slow Moving Vehicle) sign, displayed at the rear of the Tube-line Bale Feeder and use your hazard lights if the law permits. Check local road laws before transporting.
2. When transporting the Tube-line Bale Feeder on the road be aware of the width and length of the Bale Feeder, **especially while carrying a square bale.**
 1. Do not transport the machine at night, at dawn, or at dusk.
 2. Do not exceed 32kph (20mph) during transport.

Section 3 Operation



WARNING



Keep bystanders away from the machine. Failure to comply could result in death or serious injury.

NOTE: Setup instructions assume the operator already has read and has the Tube-line Bale Feeder attached to the tractor.

1. Apply hydraulic pressure.
2. Raise and lower bed.
3. Raise and lower bale loading assembly.



WARNING



Do not run with defective hoses or fittings. Make sure that there is no pressure in the hydraulic lines before checking or repairing. High-pressured hydraulics can cause death or serious injury.

7. Restart the Tube-line Bale Feeder.



WARNING



Engage the parking brake on the tractor, shut the engine down, and wait for all moving parts to stop before leaving the cab. Failure to comply could result in death or serious injury

4. Check for loose or missing nuts and bolts. Tighten any that are loose and replace any missing fasteners.
5. Make sure that all protective shields are in place and properly secured.
6. Check all hydraulic hoses and fittings to be sure they are tight and that no hose damage has occurred during mounting. Repair or replace any damaged parts before starting the machine.

Loading Bales (Wrapped Bales)

1. With rear fork assembly down reverse the unit and pierce bale.
2. Apply hydraulic pressure and lift the bale until it is approximately 4" above plastic bed.
3. Remove plastic wrap and net wrap.
4. Lower bale onto Tube-line Bale Feeder bed and release fork rack and lower into loading position.
5. Once again pierce the bale and lift the bale a few inches off the ground.

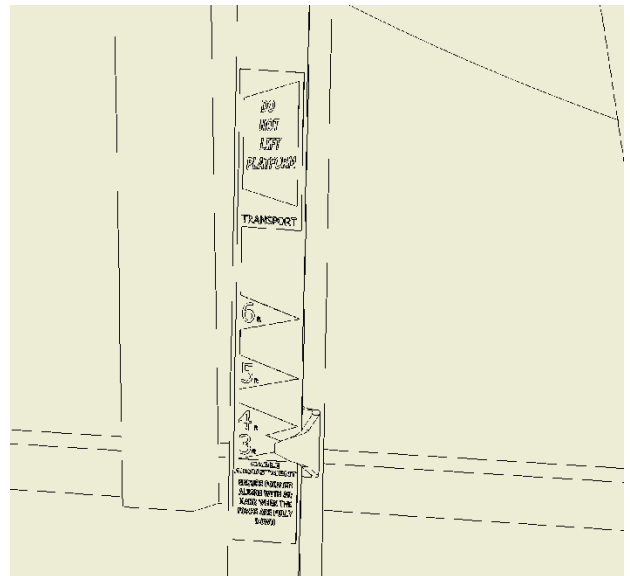
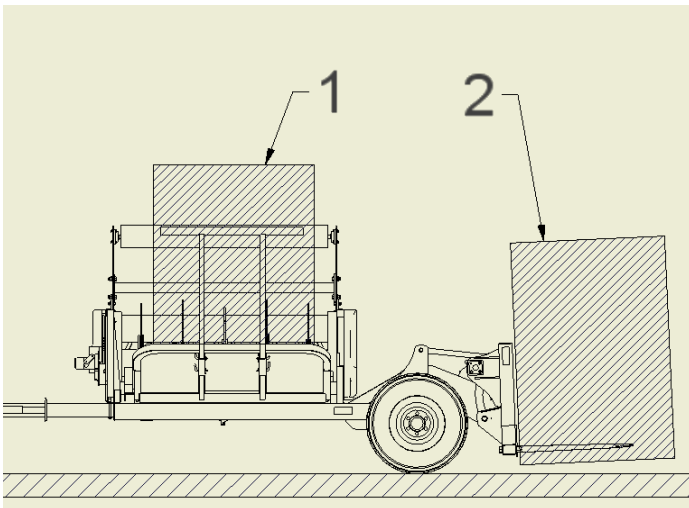
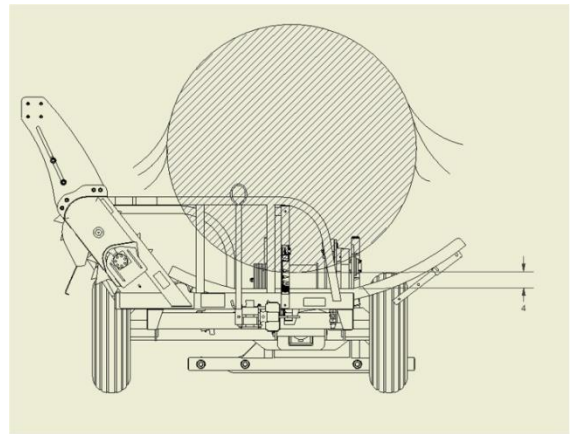
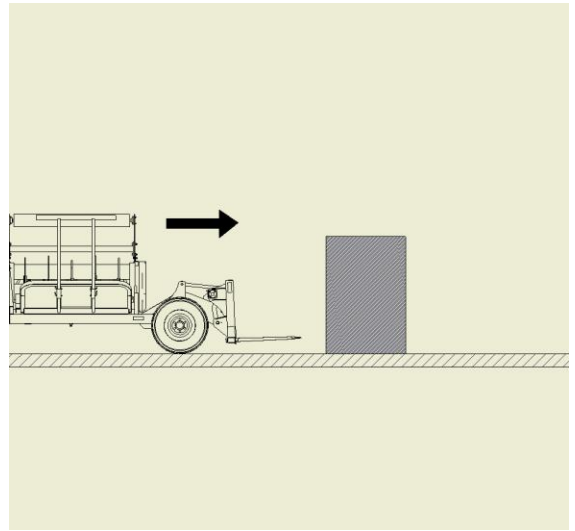

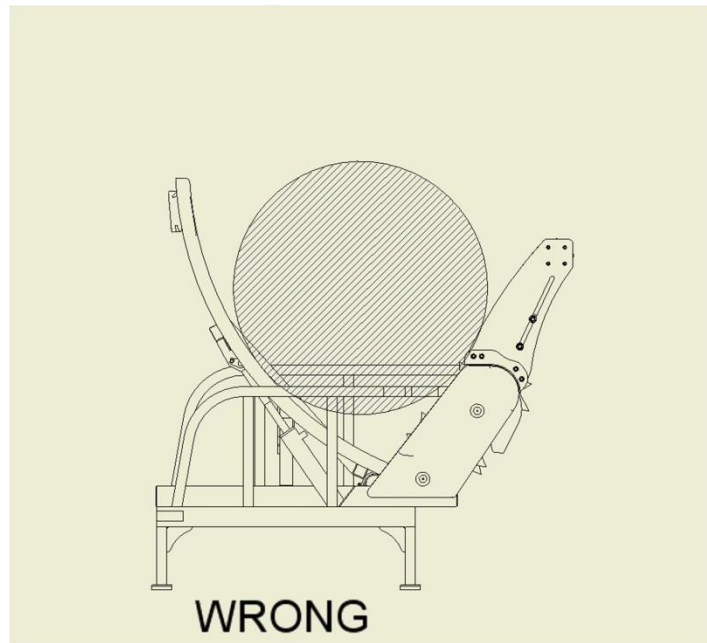
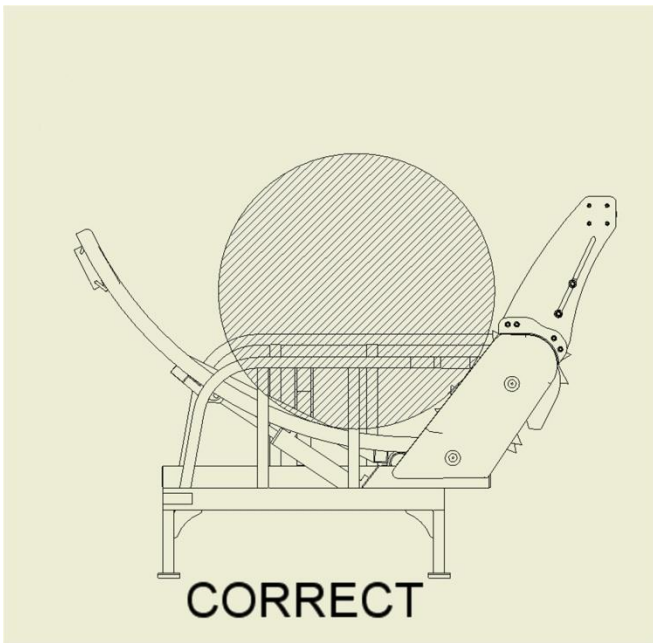

Section 4 Lubrication

Introduction

This section gives full details of the procedures necessary to maintain the Tube-line Bale Feeder at peak efficiency. Complete all checks and services in this section at the hour interval shown.

Important: Failure to complete the required maintenance at the intervals shown can cause unnecessary downtime.

The recommended lubrication intervals are for average conditions. Perform lubrication more often when operating under adverse conditions.



WARNING



Before lubricating the Tube-line Bale Feeder, always observe the following precautions:

•Turn off tractor, set parking brake, remove key and wait for all moving parts to stop before leaving cab.

Failure to comply could result in death or serious injury.

Loader Arm Assembly (1)

Apply 3 strokes of grease every 25 hours at point (1) (2 locations).

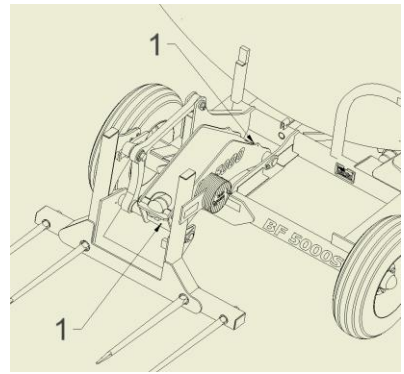

Beater Bearing (2)

Apply 3 strokes of grease every 50 hours at point (2) (4 locations).

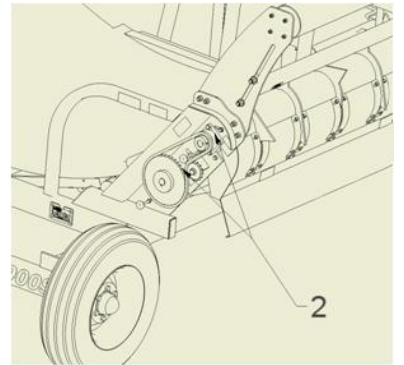

Linkage Assembly (3)

Apply 3 strokes of grease every 25 hours at point (3) (4 locations).

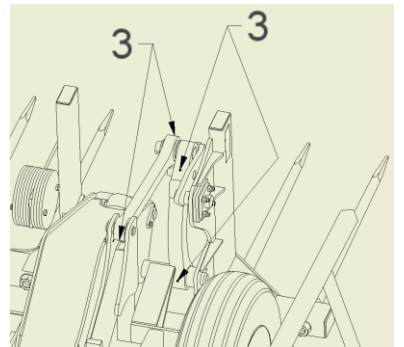

Cylinder Pivot (4)

Apply 3 strokes of grease every 50 hours at point (4) (4 locations).

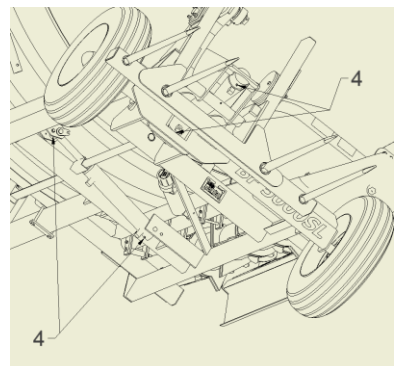

Hub (5)

Apply 3 strokes of grease every 50 hours at point (5) (2 locations).

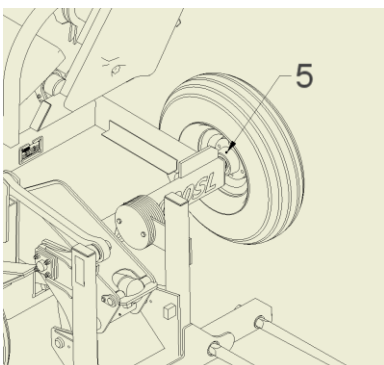

Bumper Bearing (6)

Apply 3 strokes of grease every 50 hours at point (6) (2 locations).

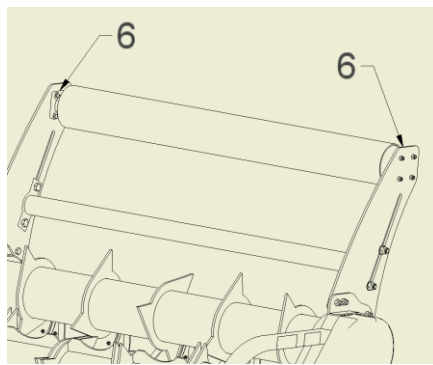

Section 5 Maintenance

Complete all checks and services in this section at the hour interval shown.

IMPORTANT: Failure to complete the required maintenance at intervals shown can cause unnecessary downtime.

The recommended intervals are for average conditions. Perform maintenance more often when operating the Tube-line BF5000 under adverse conditions.



Before performing any adjustments or maintenance on the Tube-line BF5000, observe these safety precautions:

- **Turn off tractor, set parking brake, remove key and wait for all moving parts to stop before leaving cab.**

Failure to comply could result in death or serious injury.

Careful inspection and service of the BF5000 prior to operation each day will prevent needless breakdowns and delays in the field. Make the following checks and adjustments.

End of Season Service

Prior to storing the Tube-line BF5000 during the off season, follow these steps to ensure easier preparation for the next season and longer Tube-line BF5000 life

Pack all grease point with grease (see the “Lubrication” section for grease points location).

Remove all crop material from the BF5000.

Daily Maintenance

Be alert for loose hardware and tighten or replace as required.

Lubricate the Tube-line BF5000 according to the instructions in the “Lubrication” section of this manual. Under adverse conditions, shorten the lubrication intervals.

Preseason Service

Prior to beginning the harvest after offseason storage, take the following steps be certain the Tube-line BF5000 is in good condition.

Check slot opening guide, make sure it is tight and that the beater blade clears as described in the “General Information” section.

Lubricate the Tube-line BF5000 according to the “Lubrication” section of this manual.

Tighten or replace any damaged or missing fasteners.

Section 6

Trouble Shooting

Round bales

Problem: The rotors turn, but the bale refuses to turn.

Suggested remedy: The platform is not raised high enough. The bale must be pushed against both beaters.(see pg 3-2)

Problem: Crop material jams between top beater and wiper.

Suggested remedy: The wiper guides may need adjusting. (see pg 2-3)

Problem: Several biscuits coming out at once.

Suggested remedy: The bed is too high. Lower the bed. The crop material was baled when wet, reverse beaters 2 turns then forward again.

General













Problem: The bale is dropping too hard onto platform.

Suggested Remedy: Spear bale lower when loading

Problem: Spear frame does not trip before the bale rests on the platform.

Suggested Remedy: Spear bale higher when loading

UNIFIED INCH BOLT AND CAP SCREW TORQUE VALUES

SAE Grade and Head Markings	1 or 2 ^b		5	5.1	5.2	8	8.2
	NO MARK						
SAE Grade and Nut Markings	2		5		8		
	NO MARK						

Size	Grade 1				Grade 2 ^b				Grade 5, 5.1, or 5.2				Grade 8 or 8.2			
	Lubricated ^a		Dry ^a		Lubricated ^a		Dry ^a		Lubricated ^a		Dry ^a		Lubricated ^a		Dry ^a	
	N-m	lb-ft	N-m	lb-ft	N-m	lb-ft	N-m	lb-ft	N-m	lb-ft	N-m	lb-ft	N-m	lb-ft	N-m	lb-ft
1/4	3.7	2.8	4.7	3.5	6	4.5	7.5	5.5	9.5	7	12	9	13.5	10	17	12.5
5/16	7.7	5.5	10	7	12	9	15	11	20	15	25	18	28	21	35	26
3/8	14	10	17	13	22	16	27	20	35	26	44	33	50	36	63	46
7/16	22	16	28	20	35	26	44	32	55	41	70	52	80	58	100	75
1/2	33	25	42	31	53	39	67	50	85	63	110	80	120	90	150	115
9/16	48	36	60	45	75	56	95	70	125	90	155	115	175	130	225	160
5/8	67	50	85	62	105	78	135	100	170	125	215	160	240	175	300	225
3/4	120	87	150	110	190	140	240	175	300	225	375	280	425	310	550	400
7/8	190	140	240	175	190	140	240	175	490	360	625	450	700	500	875	650
1	290	210	360	270	290	210	360	270	725	540	925	675	1050	750	1300	975
1-1/8	400	300	510	375	400	300	510	375	900	675	1150	850	1450	1075	1850	1350
1-1/4	570	425	725	530	570	425	725	530	1300	950	1650	1200	2050	1500	2600	1950
1-3/8	750	550	950	700	750	550	950	700	1700	1250	2150	1550	2700	2000	3400	2550
1-1/2	1000	725	1250	925	990	725	1250	930	2250	1650	2850	2100	3600	2650	4550	3350

DO NOT use these values if a different torque value or tightening procedure is given for a specific application. Torque values listed are for general use only. Check tightness of fasteners periodically.

Shear bolts are designed to fail under predetermined loads. Always replace shear bolts with identical grade.

^a "Lubricated" means coated with a lubricant such as engine oil, or fasteners with phosphate and oil coatings. "Dry" means plain or zinc plated without any lubrication.

^b Grade 2 applies for hex cap screws (not hex bolts) up to 152 mm (6-in.) long. Grade 1 applies for hex cap screws over 152 mm (6-in.) long, and for all other types of bolts and screws of any length.

Fasteners should be replaced with the same or higher grade. If higher grade fasteners are used, these should only be tightened to the strength of the original.

Make sure fasteners threads are clean and that you properly start thread engagement. This will prevent them from failing when tightening.

Tighten plastic insert or crimped steel-type lock nuts to approximately 50 percent of the dry torque shown in the chart, applied to the nut, not to the bolt head. Tighten toothed or serrated-type lock nuts to the full torque value.

METRIC BOLT AND CAP SCREW TORQUE VALUES

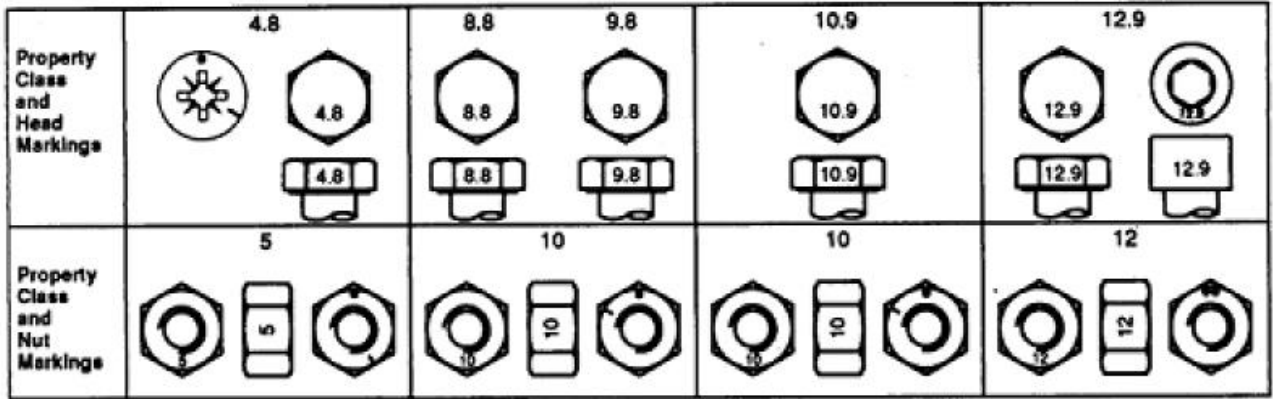

Size	Class 4.8				Class 8.8 or 9.8				Class 10.9				Class 12.9			
	Lubricated ^a		Dry ^a		Lubricated ^a		Dry ^a		Lubricated ^a		Dry ^a		Lubricated ^a		Dry ^a	
	N-m	lb-ft	N-m	lb-ft	N-m	lb-ft	N-m	lb-ft	N-m	lb-ft	N-m	lb-ft	N-m	lb-ft	N-m	lb-ft
M6	4.8	3.5	6	4.5	9	6.5	11	8.5	13	9.5	17	12	15	11.5	19	14.5
M8	12	8.5	15	11	22	16	28	20	32	24	40	30	37	28	47	35
M10	23	17	29	21	43	32	55	40	63	47	80	60	75	55	95	70
M12	40	29	50	37	75	55	95	70	110	80	140	105	130	95	165	120
M14	63	47	80	60	120	88	150	110	175	130	225	165	205	150	260	190
M16	100	73	125	92	190	140	240	175	275	200	350	255	320	240	400	300
M18	135	100	175	125	260	195	330	250	375	275	475	350	440	325	560	410
M20	190	140	240	180	375	275	475	350	530	400	675	500	625	460	800	580
M22	260	190	330	250	510	375	650	475	725	540	925	675	850	625	1075	800
M24	330	250	425	310	650	475	825	600	925	675	1150	850	1075	800	1350	1000
M27	490	360	625	450	950	700	1200	875	1350	1000	1700	1250	1600	1150	2000	1500
M30	675	490	850	625	1300	950	1650	1200	1850	1350	2300	1700	2150	1600	2700	2000
M33	900	675	1150	850	1750	1300	2200	1650	2500	1850	3150	2350	2900	2150	3700	2750
M36	1150	850	1450	1075	2250	1650	2850	2100	3200	2350	4050	3000	3750	2750	4750	3500

DO NOT use these values if a different torque value or tightening procedure is given for a specific application. Torque values listed are for general use only. Check tightness of fasteners periodically.

Shear bolts are designed to fail under predetermined loads. Always replace shear bolts with identical property class.

Fasteners should be replaced with the same or higher property class. If higher property class fasteners are used, these should only be tightened to the strength of the original.

^a "Lubricated" means coated with a lubricant such as engine oil, or fasteners with phosphate and oil coatings. "Dry" means plain or zinc plated without any lubrication.

Make sure fasteners threads are clean and that you properly start thread engagement. This will prevent them from failing when tightening.

Tighten plastic insert or crimped steel-type lock nuts to approximately 50 percent of the dry torque shown in the chart, applied to the nut, not to the bolt head. Tighten toothed or serrated-type lock nuts to the full torque value.

TUBE•LINE™
MANUFACTURING LTD